

F5

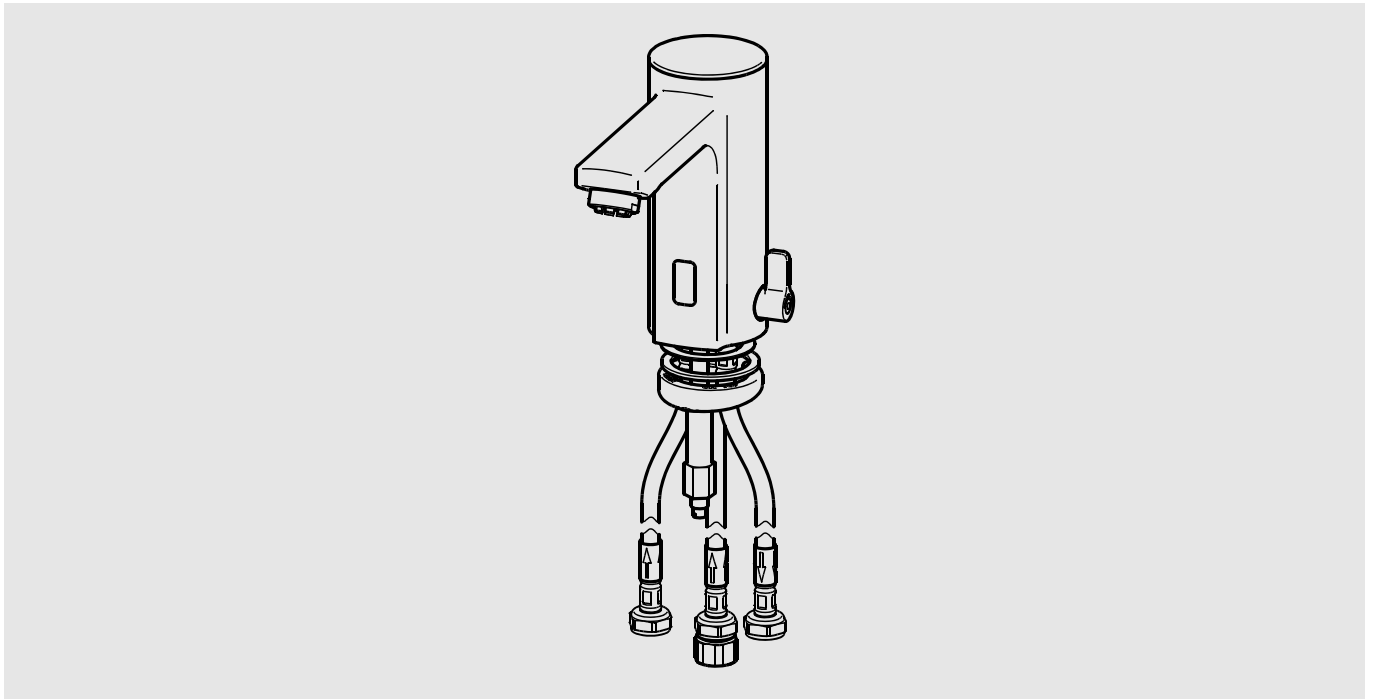

F5EM1005

2030031350

7612982232268

DE	Montage- und Betriebsanleitung	Elektronik-Standbatterie
EN	Installation and operating instructions	Electronic pillar mixer
FR	Notice de montage et de mise en service	Robinetterie électronique de montage sur plage
ES	Instrucciones de montaje y servicio	Grifo de pie con sistema electrónico
IT	Istruzioni per il montaggio e l'uso	
NL	Montage- en bedrijfsinstructies	Elektronische wastafelmengkraan
PL	Instrukcja montażu i obsługi	Elektroniczna bateria pionowa
SV	Monterings- och driftinstruktion	
CS	Návod pro montáž a provoz	
FI	Asennus- ja käyttöohje	Elektroninen pylväshana
RU	Инструкция по монтажу и вводу в эксплуатацию	

ZMI_001_2030031350-F5EM1005_#SALL_#AQU_#Y1_fm / 26.01.17

*Make
it
Wonderful*

FRANKE

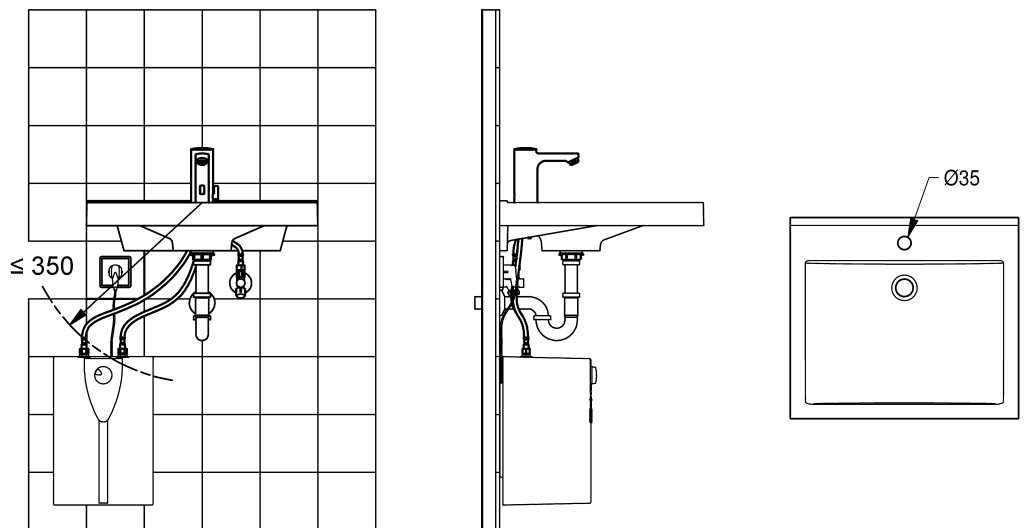
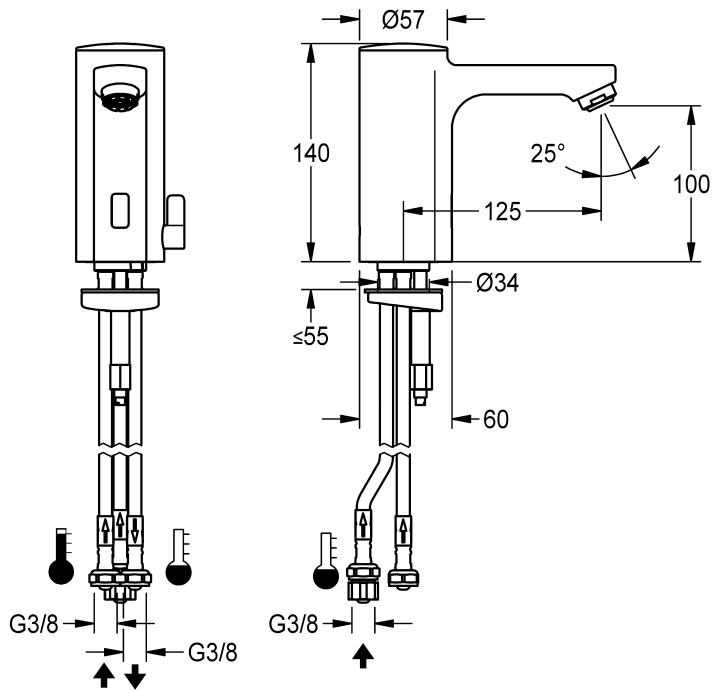
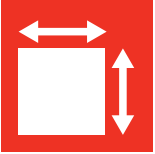
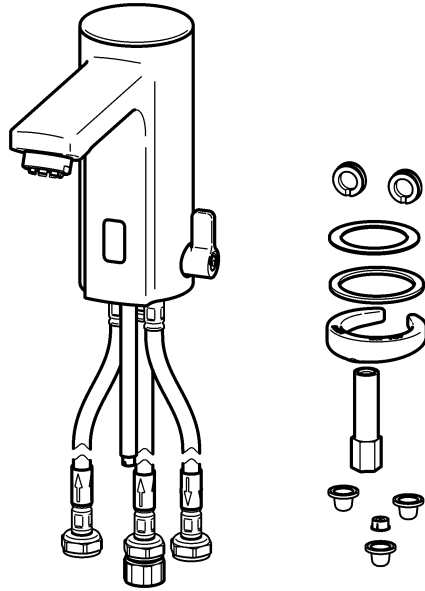

EN

Installation and operating instructions

Important notes

- ▶ Before installing flush piping system!
- ▶ After completing the installation, set the temperature limiter!
- ▶ The fitting must be operated only with original mesh filters!
- ▶ The fitting must be checked and maintained at regular intervals depending on the water quality and in accordance with the local conditions, and rules and regulations applicable at the site.

Technical data

- ▶ Minimum flow pressure 1.0 bar
- ▶ Maximum operating pressure 10 bar
- ▶ Recommended flow pressure 1-5 bar
- ▶ Volume flow at 3 bar flow pressure 4,8 l/min
- ▶ maximum operating temperature
 - continuous operation 70° C
 - short-term (<10 min) 80° C
- ▶ Voltage supply with lithium battery CRP2 6 V DC
- ▶ Power consumption 1,5 W
- ▶ Type of protection IP 59K

DE

Montage- und Betriebsanleitung

Wichtige Hinweise

- ▶ Vor Installation Rohrleitungen gemäß DIN 1988 spülen!
- ▶ Nach erfolgter Montage die Temperaturbegrenzung einstellen!
- ▶ Armatur nur mit original Sieben betreiben!
- ▶ In Abhängigkeit von der Wasserqualität, den örtlichen Gegebenheiten und den vor Ort geltenden Bestimmungen die Armatur in regelmäßigen Abständen prüfen und warten.

Technische Daten

- ▶ Mindestfließdruck 1,0 bar
- ▶ Maximaler Betriebsdruck 10 bar
- ▶ Empfohlener Fließdruck 1-5 bar
- ▶ Volumenstrom bei 3 bar Fließdruck 4,8 l/min
- ▶ maximale Betriebstemperatur
 - Dauerbetrieb 70° C
 - Kurzzeit (<10 min) 80° C
- ▶ Spannungsversorgung mit Lithium Batterie CRP2 6 V DC
- ▶ Leistungsaufnahme 1,5 W
- ▶ Schutzart IP 59K

Ważne wskazówki

- ▶ Przed instalacją przepłukać rury!
- ▶ Po zakończeniu montażu ustawić ograniczenie temperatury!
- ▶ Armatury należy używać wyłącznie z oryginalnymi sitkami!
- ▶ Armaturę należy poddawać regularnej kontroli i konserwacji w zależności od jakości wody, warunków lokalnych i obowiązujących przepisów.

Dane techniczne

- ▶ Minimalne ciśnienie przepływu 1,0 bar
- ▶ Maksymalne ciśnienie robocze 10 barów
- ▶ Zalecane ciśnienie przepływu 1-5 barów
- ▶ Objętościowe natężenie przepływu przy ciśnieniu 3 barów 4,8 l/min
- ▶ Maksymalna temperatura eksploatacji
 - Praca stała 70° C
 - Czas krótki (<10 min) 80° C
- ▶ Zasilanie elektryczne baterią litową CRP2 6 V DC
- ▶ Pobór mocy 1,5 W
- ▶ Rodzaj ochrony IP 59K

Viktiga informationer

- ▶ Spola igenom rörledningarna före installation!
- ▶ När monteringen har gjorts skall temperaturbegränsningen ställas in!
- ▶ Använd armaturen endast med originalsilar!
- ▶ Kontrollera och serva armaturen med intervaller som bestäms av vattenkvaliteten samt de lokala förhållandena och de bestämmelser som gäller där.

Tekniska data

- ▶ Minsta hydrauliska tryck 1,0 bar
- ▶ Maximalt drifttryck 10 bar
- ▶ Rekommenderat hydrauliskt tryck 1-5 bar
- ▶ Volymström vid 3 bar hydrauliskt tryck 4,8 l/min
- ▶ Maximal driftstemperatur
 - Kontinuerlig drift 70° C
 - Kort tid (< 10 min) 80° C
- ▶ Spänningsförsörjning med litiumbatteri CRP2 6 V DC
- ▶ Effektbehov 1,5 W
- ▶ Skyddsklass IP 59K

FR

Notice de montage et de mise en service

Remarques importantes

- ▶ Rincer les conduites avant d'installer !
- ▶ Une fois le montage terminé, régler la limitation de température !
- ▶ Ne faire fonctionner la robinetterie qu'avec les filtres d'origine !
- ▶ En fonction de la qualité de l'eau, ainsi que des conditions et des dispositions locales, il convient de contrôler et d'entretenir la robinetterie à intervalles réguliers.

Données techniques

- ▶ Pression dynamique minimale 1,0 bar
- ▶ Pression de service maximale 10 bars
- ▶ Pression dynamique recommandée 1-5 bars
- ▶ Débit volumique pour 3 bars de pression dynamique 4,8 l/min
- ▶ Température de fonctionnement maximale
 - Fonctionnement continu 70° C
 - Courte période (< 10 min) 80° C
- ▶ Alimentation en tension avec pile au lithium CRP2 6 V DC
- ▶ Puissance absorbée 1,5 W
- ▶ Type de protection IP 59K

CS

Návod pro montáž a provoz

Důležité pokyny

- ▶ Před instalací potrubí propláchněte!
- ▶ Po provedené montáži nastavit omezení teploty!
- ▶ Provozovat armaturu jen s originálními sítky!
- ▶ V závislosti na kvalitě vody, místních podmínkách a předpisech platných v místě instalace je nutné provádět v pravidelných intervalech kontrolu a údržbu armatury.

Technické údaje

- ▶ Minimální průtočný tlak 1,0 bar
- ▶ Maximální provozní tlak 10 bar
- ▶ Doporučený průtočný tlak 1-5 bar
- ▶ Průtok při průtočném tlaku 3 bar 4,8 l/min
- ▶ Maximální provozní teplota
 - Doba provozu 70° C
 - Krátký čas (< 10 min.) 80° C
- ▶ Napájení lithiovou baterií CRP2 6 V DC
- ▶ Příkon 1,5 W
- ▶ Krytí IP 59K

ES

Instrucciones de montaje y servicio

Indicaciones importantes

- ▶ ¡Enjuagar las tuberías antes de instalar!
- ▶ ¡Ajuste el límite de temperatura tras realizar el montaje!
- ▶ ¡La grifería debe hacerse funcionar únicamente con los tamices originales!
- ▶ En función de la calidad del agua, las condiciones locales y la legislación vigente, realizar las inspecciones y el mantenimiento de la grifería a intervalos regulares.

Datos técnicos

- ▶ Presión mínima de flujo 1,0 bar
- ▶ Presión máxima de servicio 10 bares
- ▶ Presión de flujo recomendada 1-5 bares
- ▶ Flujo volumétrico con 3 bares de presión de flujo 4,8 l/min
- ▶ Temperatura de servicio máxima
 - Funcionamiento continuo 70° C
 - Tiempo breve (< 10 min) 80° C
- ▶ Alimentación de corriente con batería de litio CRP2 6 V DC
- ▶ Consumo de potencia 1,5 W
- ▶ Modo de protección IP 59K

FI

Asennus- ja käyttöohje

Tärkeitä ohjeita

- ▶ Huuhtele putkijohdot ennen asennusta!
- ▶ Säädä asennuksen jälkeen lämpötilan rajoitus!
- ▶ Käytä varusteet vain alkuperäisten sihtien!
- ▶ Hana tulee tarkistaa ja huoltaa säännöllisin väliajoin veden laadusta, paikallisista oloista ja paikalla voimassa olevista määräyksistä riippuen.

Tekniset tiedot

- ▶ Vähimmäisvirtauspaine 1,0 bar
- ▶ Suurin käyttöpaine 10 bar
- ▶ Suositeltava virtauspaine 1-5 bar
- ▶ Tilavuusvirta 3 barin virtauspaineella 4,8 l/min
- ▶ Maksimaalinen käyttölämpötila
 - Jatkuva käyttö 70° C
 - Lyhyt aika (<10 min) 80° C
- ▶ Jännitteensyöttö litiumparistolla CRP2 6 V DC
- ▶ Tehonkulutus 1,5 W
- ▶ Suojaustapa IP 59K

IT

Istruzioni per il montaggio e l'uso

Avvertenze importanti

- ▶ Sциacquare le tubazioni prima di installare!
- ▶ Una volta terminata l'installazione, impostare la limitazione di temperatura!
- ▶ Utilizzare la rubinetteria esclusivamente con i filtri originali!
- ▶ Controllare e sottoporre a manutenzione l'apparecchio ad intervalli regolari, in funzione della qualità dell'acqua, delle caratteristiche locali e delle vigenti disposizioni locali.

Specifiche tecniche

- ▶ Pressione idraulica min. 1,0 bar
- ▶ Pressione di esercizio max. 10 bar
- ▶ Pressione idraulica consigliata 1-5 bar
- ▶ Portata volumetrica a 3 bar di pressione idraulica 4,8 l/min
- ▶ Temperatura massima di esercizio
 - Funzionamento continuo 70 °C
 - Brevemente (<10 min) 80 °C
- ▶ Alimentazione di tensione con batteria al litio CRP 2 di 6 V DC
- ▶ Potenza assorbita 1,5 W
- ▶ Tipo di protezione IP 59K

RU

Инструкция по монтажу и вводу в эксплуатацию

Важные указания

- ▶ Перед инсталляцией промыть трубки!
- ▶ После монтажа отрегулировать температурный предел!
- ▶ Эксплуатировать арматуру только с оригинальными фильтрами!
- ▶ Арматуру необходимо регулярно чистить и обслуживать в зависимости от качества воды, местных условий и действующих в месте эксплуатации предписаний.

Технические характеристики

- ▶ Минимальный гидравлический напор 1,0 бар
- ▶ Максимальное рабочее давление 10 бар
- ▶ Рекомендуемый гидравлический напор 1-5 бар
- ▶ Объёмный расход при гидравлическом напоре 3 бар 4,8 л/мин
- ▶ Максимальная рабочая температура
 - Непрерывный режим работы 70 °C
 - Короткое время (<10 мин) 80 °C
- ▶ Источник питания - литиевая батарея CRP 2 6 В постоянного тока
- ▶ Потребляемая мощность 1,5 Вт
- ▶ Вид защиты IP 59K

Belangrijke aanwijzingen

- ▶ Voor installatie buisleidingen spoelen!
- ▶ Na de montage de temperatuurbegrenzing instellen!
- ▶ Armatuur alleen met originele zeven gebruiken!
- ▶ Afhankelijk van de waterkwaliteit, de plaatselijke omstandigheden en de plaatselijke voorschriften de armatuur regelmatig controleren en onderhouden.

Technische gegevens

- ▶ Minimale dynamische druk 1,0 bar
- ▶ Maximale werkdruk 10 bar
- ▶ Aanbevolen dynamische druk 1-5 bar
- ▶ Volumestroom bij 3 bar dynamische druk 4,8 l/min
- ▶ Maximale bedrijfstemperatuur
 - Continubedrijf 70 °C
 - Kortstondig (<10 min) 80 °C
- ▶ Spanningsvoorziening d.m.v. lithiumbatterij CRP2 6 V DC
- ▶ Opgenomen vermogen 1,5 W
- ▶ Veiligheidsgraad IP 59K

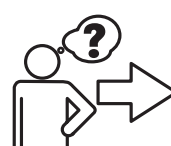
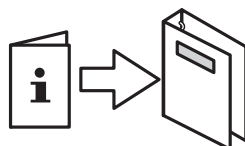
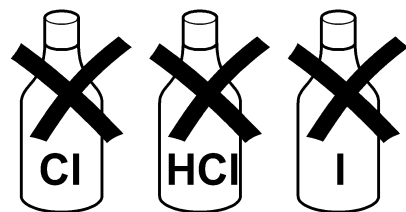
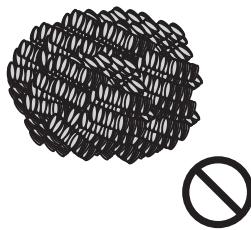

www.franke.com

1. Montage

EN Installation
FR Montage
ES Montaje
IT Montaggio

NL Montage
PL Montaż
SV Montering

CS Montáž
FI Asennus
RU Монтаж



 13 mm

 19 mm

1

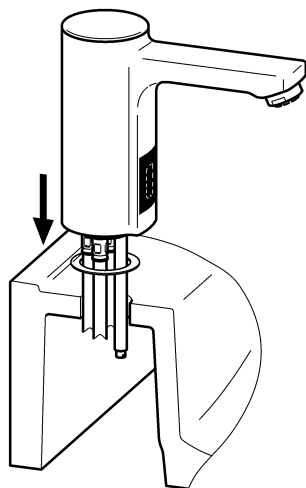

2

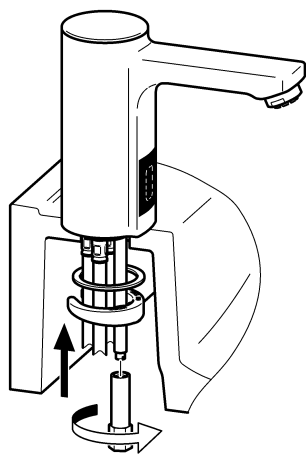

3

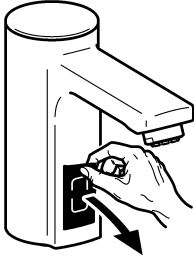

4

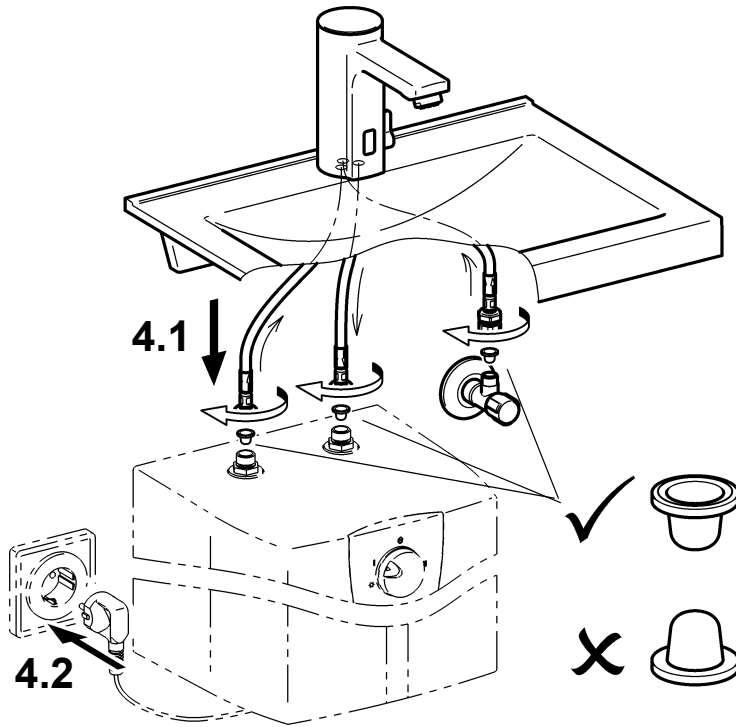

5

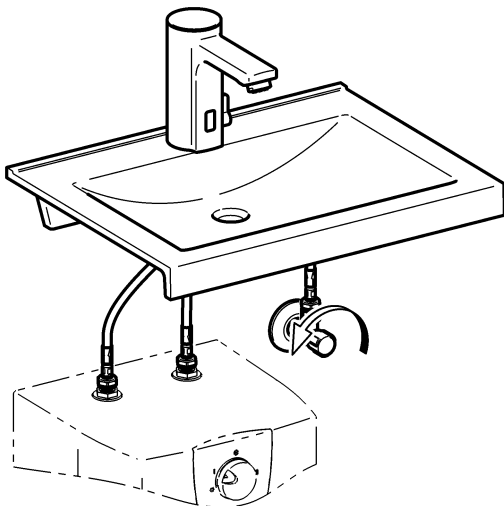

2. Funktion

EN Function
FR Fonctionnement
ES Función
IT Funzionamento

NL Werking
PL Funkcja
SV Funktion

CS Funkce
FI Toiminto
RU Функционирование

1

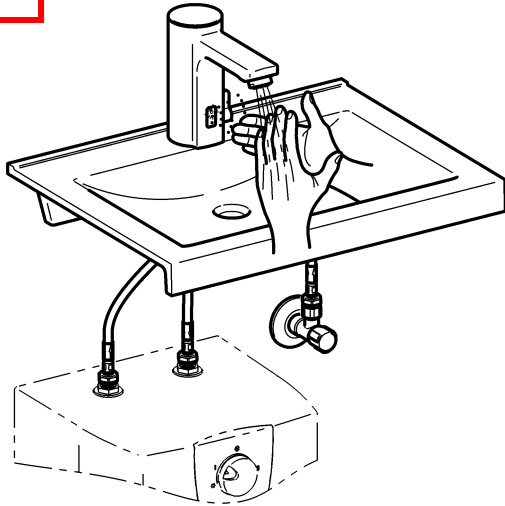

2

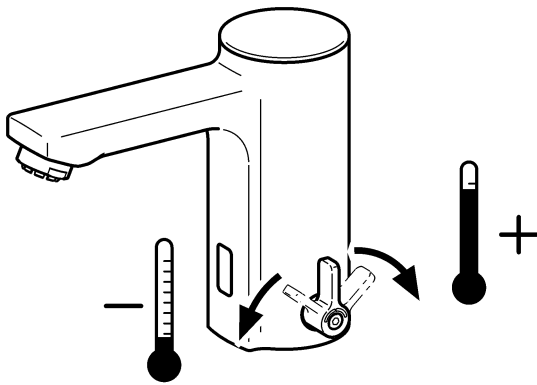
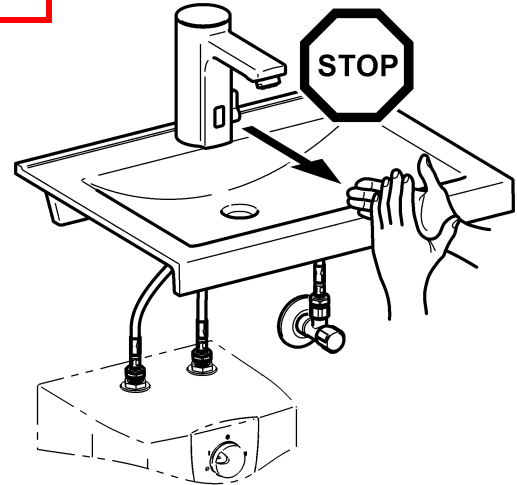

3. Hygienespülung ein- / ausschalten

EN Switching hygiene flushing on/off	NL Hygiënische spoeling in-/uitschakelen	CS Zapněte/vypněte hygienické propláchnutí
FR Activer/désactiver le rinçage hygiénique	PL Włączyć/wyłączyć spłukiwanie higieniczne	FI HygieniahuuhTELun päälle-/ pois päältä kytkeminen
ES Activar/Desactivar el aclarado higiénico	SV Koppla hygienspolningen till / från	RU Гигиеническое промывание включить/выключить
IT Attivare/disattivare lo sciacquo igienico		

- EN**
- ▶ Ensure open outlet.
 - ▶ After 24h of non-use, water flows 30 s
- DE**
- ▶ Freien Auslauf gewährleisten.
 - ▶ Nach 24 h Nichtbenutzung fließt 30 s Wasser.
- FR**
- ▶ Garantir un écoulement libre.
 - ▶ L'eau s'écoule pendant 30 s. après 24 h de non utilisation.
- ES**
- ▶ Garantizar una salida libre.
 - ▶ Si no se realiza ningún uso durante 24 horas, fluye agua durante 30 segundos.
- IT**
- ▶ Garantire l'erogazione libera.
 - ▶ Dopo 24h di inutilizzo scorre acqua per 30 s.
- NL**
- ▶ Vrije uitloop garanderen.
 - ▶ Na 24 uur niet te zijn gebruikt stroomt er gedurende 30 s. water.
- PL**
- ▶ Zapewnić swobodny wylot.
 - ▶ Po 24 godz. niekorzystania przez 30 s. wypływa woda.
- SV**
- ▶ Garantera fritt avlopp.
 - ▶ Vatten flyter 30 s efter 24 timmars användningspaus.
- CS**
- ▶ Zajistěte volný odtok.
 - ▶ Při nepoužívání 24 h nechte 30 s téct vodu.
- FI**
- ▶ Vapaan virtauksen takaaminen.
 - ▶ Käyttämättömänä 24 h jälkeen virtaa vettä 30 s.
- RU**
- ▶ Обеспечить беспрепятственный слив
 - ▶ После того, как устройство не используется в течение 24 ч, в течение 30 сек течёт вода.

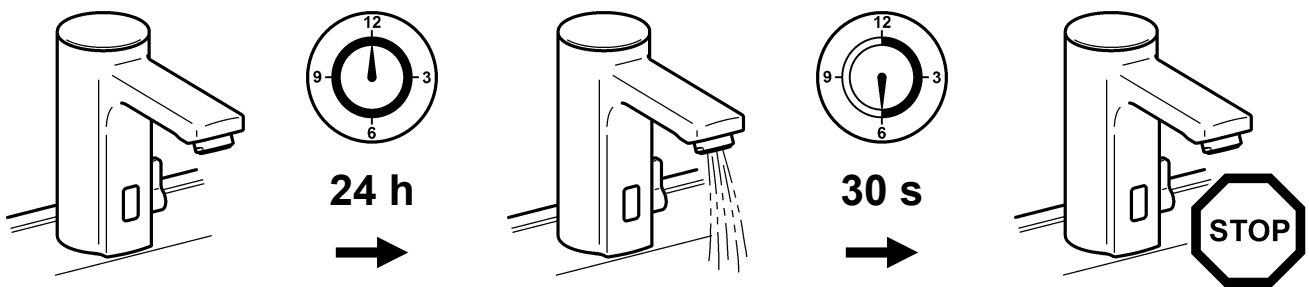



4 mm

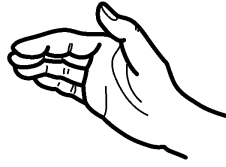

3.

1

7

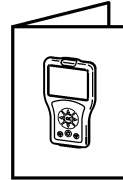
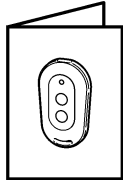
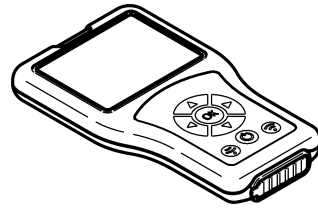

1

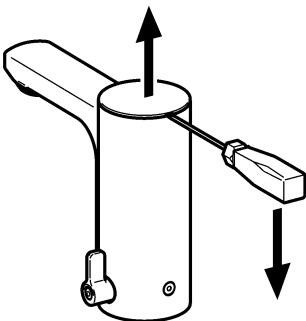

2

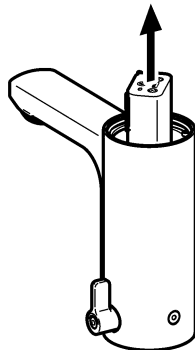

3

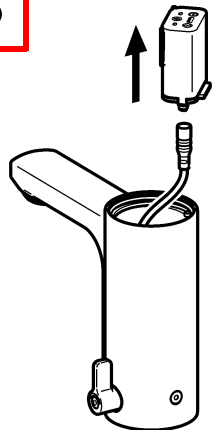

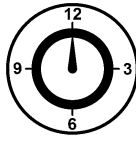

60 s



4

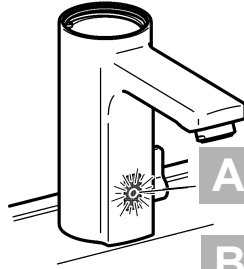
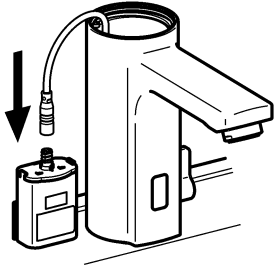

A 2x    

B 1x    

5

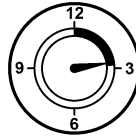
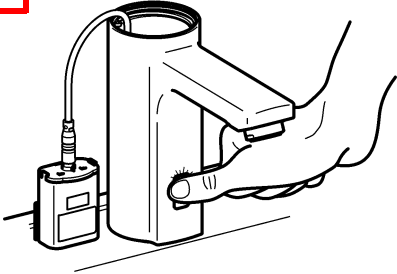

>12 s

6

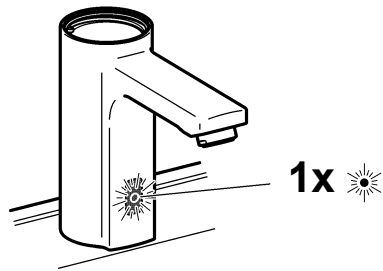
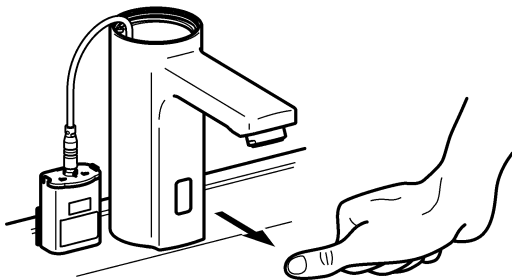

1x 

A

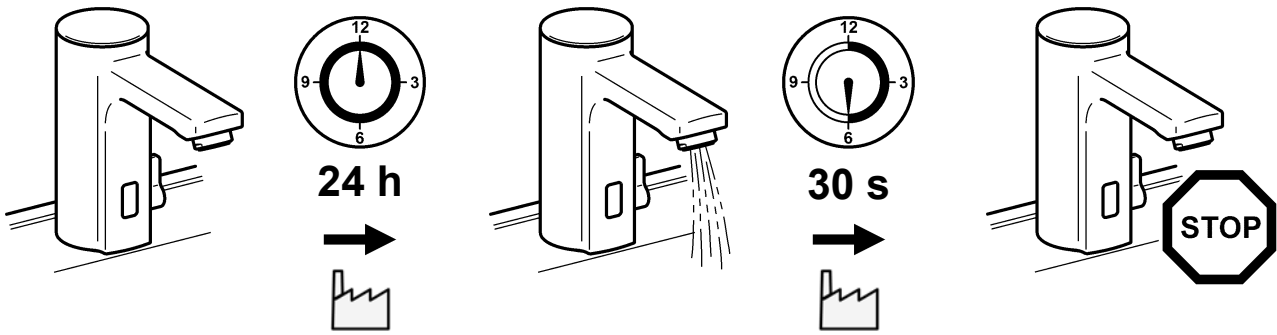

B

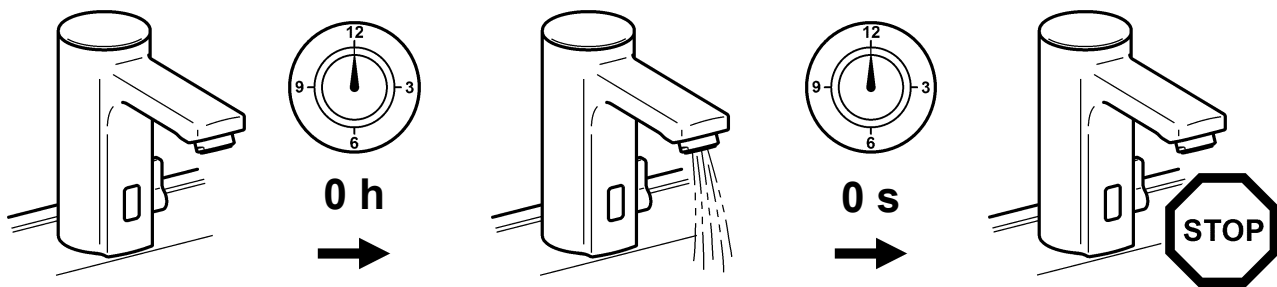

7

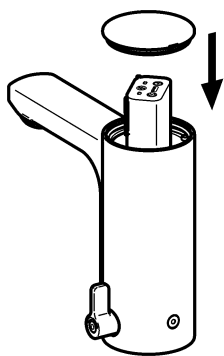

4. Armatur ausschalten

EN Switch off the valve

FR Désactiver la robinetterie

ES Desconectar la grifería

IT Disattivazione della rubinetteria

NL Armatuur uitschakelen

PL Wyłączenie baterii

SV Avstängning av armatur

CS Vypnout armaturu

FI Laitteen kytkeminen pois päältä

RU отключить оборудование

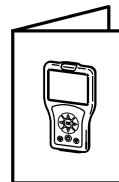
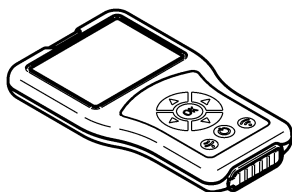

5. Dauerlauf starten

EN Start continual flow

FR Démarrer la marche continue

ES Iniciar el enjuague continuo

IT Avviare l'erogazione continua

NL Continue stroming starten

PL Uruchomić stały wypływ wody

SV Starta kontinuerlig drift

CS Spustit trvalý provoz

FI Tuotantokäytön aloittaminen

RU запустить ресурс

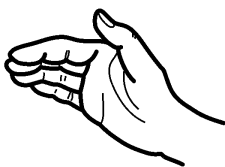

5.

1

- 2

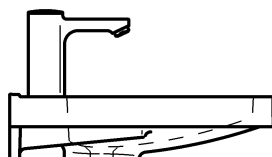
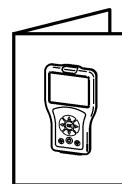
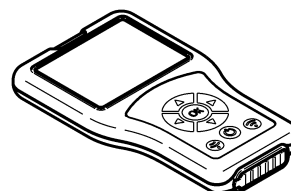

11.

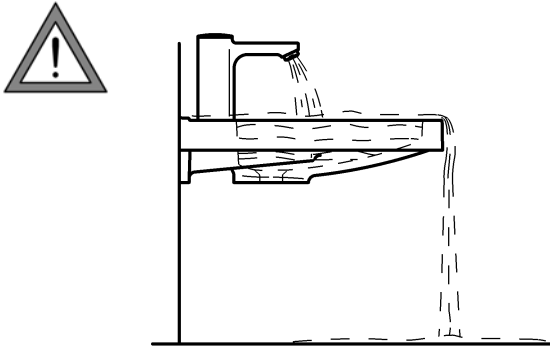

1

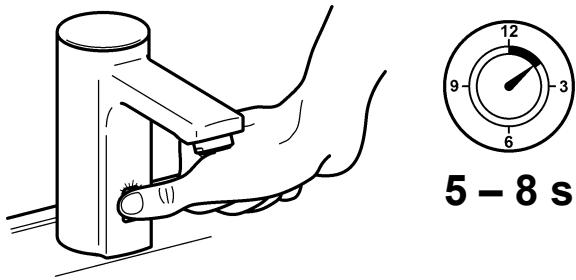

2

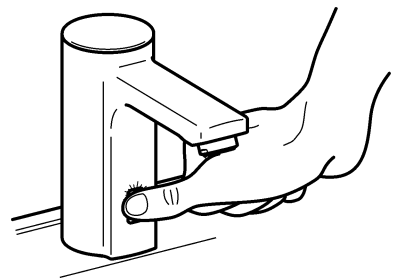
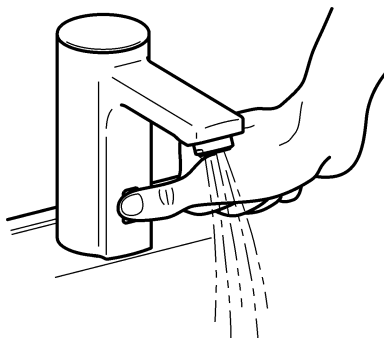
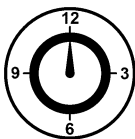
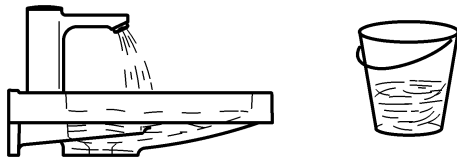
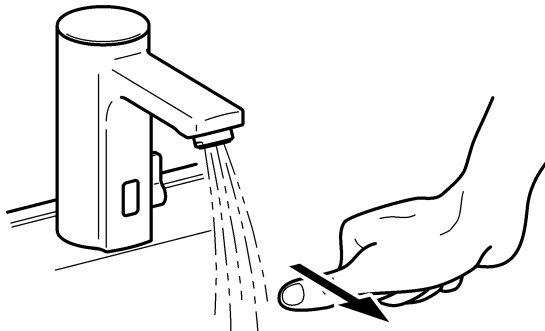

6. Reinigungsabschaltung einschalten

EN Switch on cleaning switch-off	NL Inschakelen van de reiniging shutdown	CS Vypínač pro čištění
FR Activer l'arrêt de nettoyage	PL Włączanie wyłączenia na czas czyszczenia	FI Aktivoida pesuseisokkien
ES Activar el apagado de limpieza	SV Aktivera rengörings avstängning	RU активировать чистка завершение работы
IT Attivare dello spegnimento per pulizia		

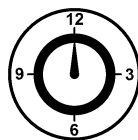
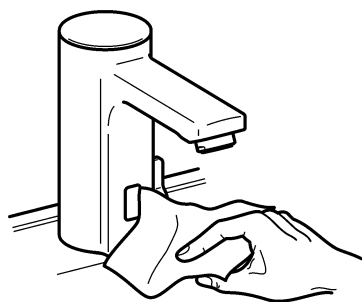

60 s

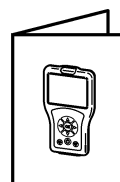
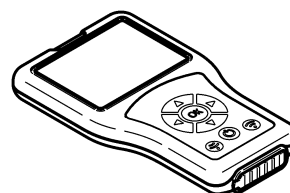
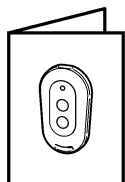

7. Erkennungs-Rückmeldung einschalten

EN
FR
ES
IT

NL
PL
SV

CS
FI
RU

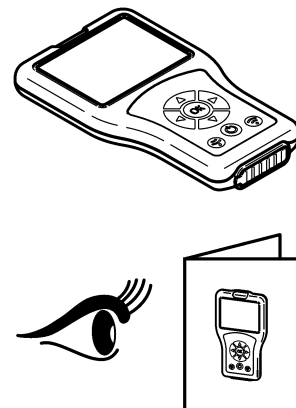
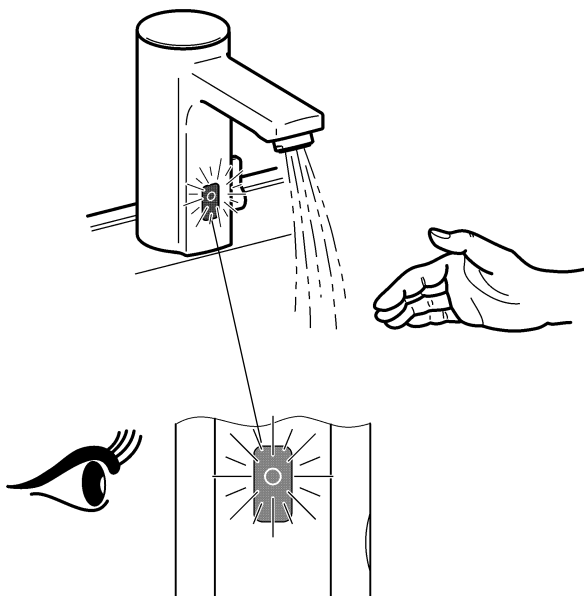
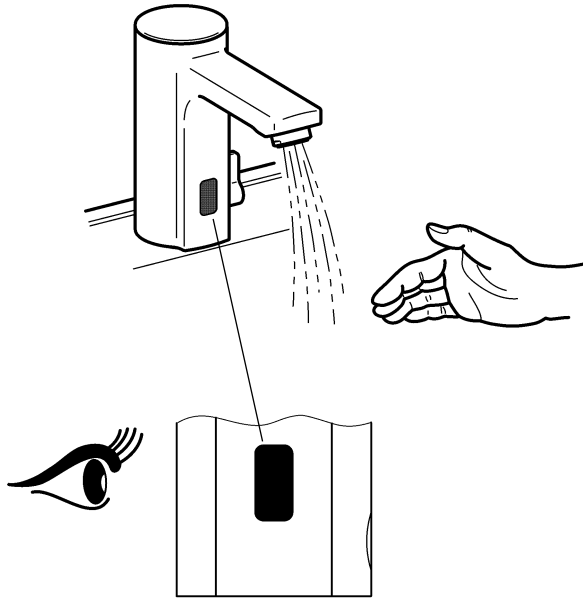

8. Körpererkennung einschalten

EN
FR
ES
IT

NL
PL
SV

CS
FI
RU

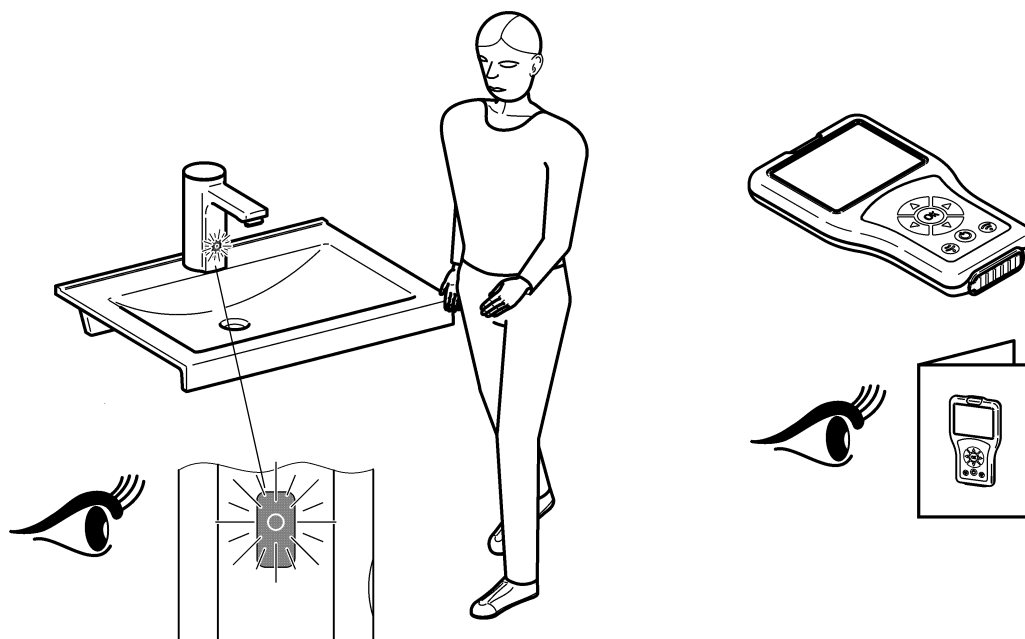
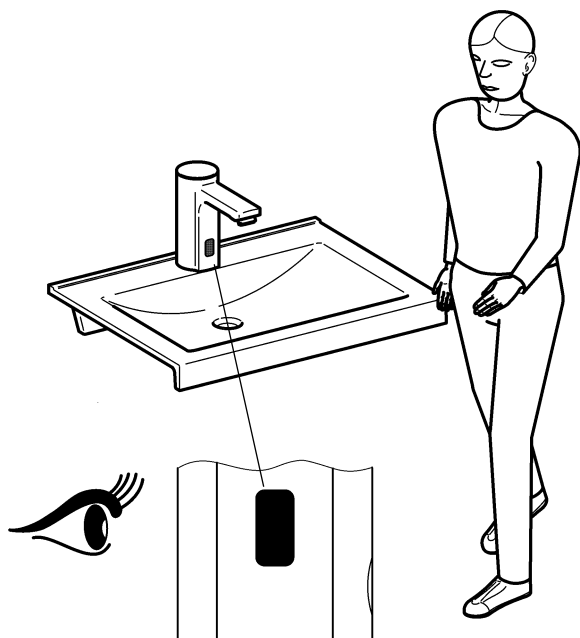

9. Reichweite einstellen

EN Adjusting the range

FR Réglage de la portée

ES Ajuste del alcance

IT Impostazione della portata

NL Actieradius instellen

PL Ustawienie zasięgu

SV Ställa in räckvidden

CS Nastavení dosahu

FI Tunnistusetäisyyden säätäminen

RU Настройка дальности действия

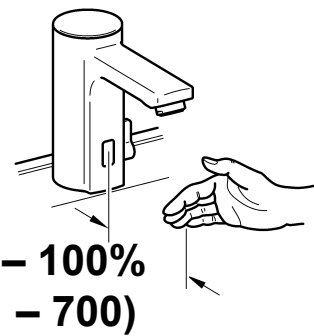
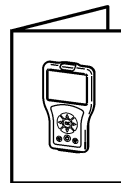
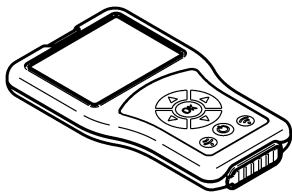
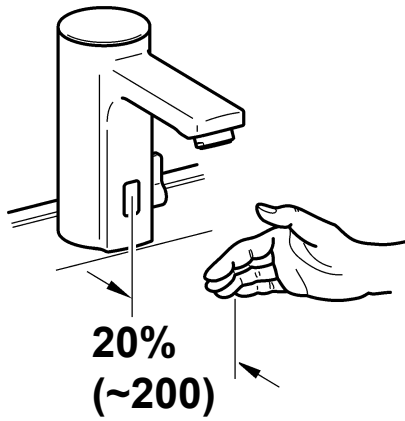

10. Hygienespülung einstellen

EN Setting the hygiene flush	NL Instellen van de hygiënespoeling	CS Nastavení hygienického proplachování
FR Réglage de la rinçage d'hygiène	PL Ustawianie spłukiwania higienicznego	FI Hygieniahuuhtelun säätäminen
ES Ajuste del higiene enjuague	SV Ställa in hygienspolning	RU установив гигиена смыва
IT Impostare lo igiene risciacquo		

- EN**
▶ I: Interval adjustable in h
▶ II: Flow duration adjustable in s
- DE**
▶ I: Intervall einstellbar in h
▶ II: Fließzeit einstellbar in s
- FR**
▶ I: intervalle réglable en h
▶ II: durée d'écoulement réglable en s
- ES**
▶ I: Intervalo ajustable en horas
▶ II: Tiempo de flujo activable en seg
- IT**
▶ I: intervallo impostabile in h
▶ II: durata di flusso impostabile in s
- NL**
▶ I: Interval instelbaar in u
▶ II: Stromingstijd instelbaar in s
- PL**
▶ I: odstęp czasu regulowany w godzinach
▶ II: czas przepływu regulowany w sekundach
- SV**
▶ I: Intervall kan ställas in i timmar
▶ II: Flödestid kan ställas in i sekunder
- CS**
▶ I: Interval s nastavením v h
▶ II: Doba průtoku s nastavením v s
- FI**
▶ I: Aikaväli, asetettavissa h
▶ II: Virtausaika, asetettavissa s
- RU**
▶ I: интервал задается в ч
▶ II: время течения задается в сек.

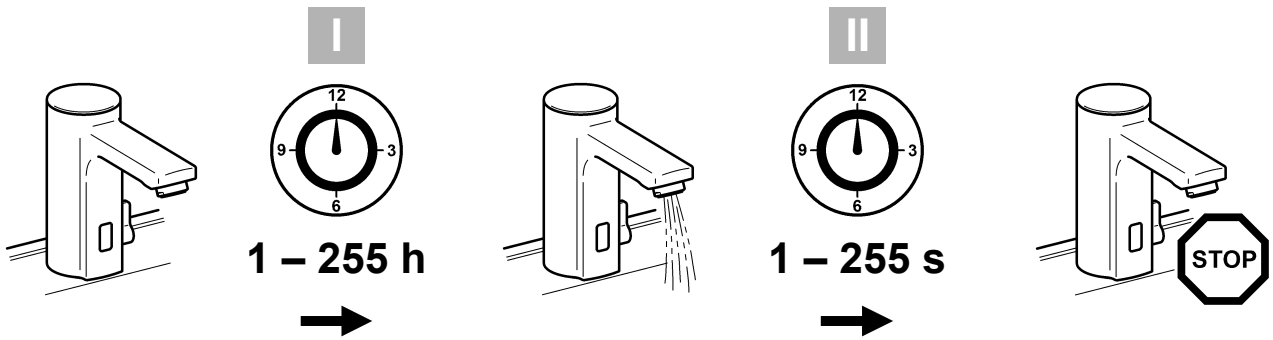
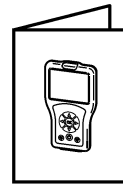
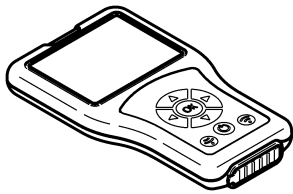
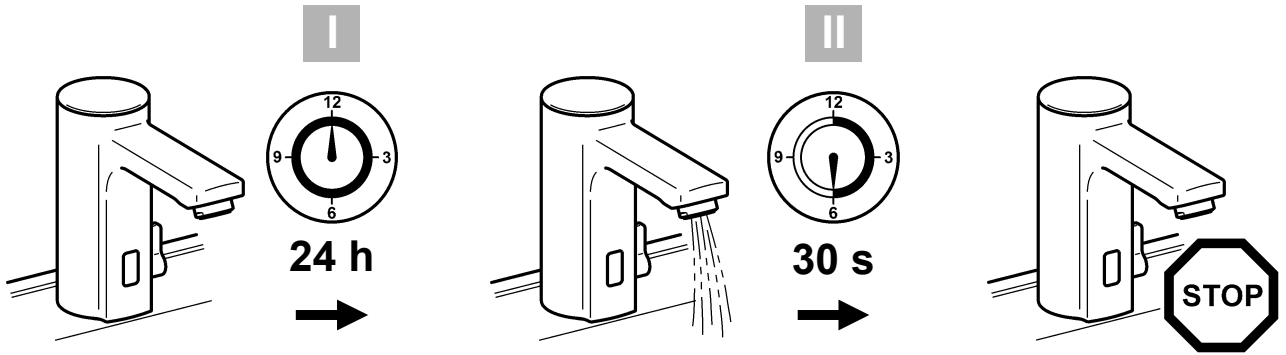

11. Dauerlauf einstellen

EN Setting continuous operating mode	NL Continue stroming instellen	CS Nastavení pomalejšího toku
FR Réglage du fonctionnement en continu	PL Ustawienie ciągłego wypływu	FI Tuotantokäytön säätäminen
ES Ajuste del funcionamiento ininterrumpido	SV Ställa in permanent flöde	RU Настройка непрерывного режима
IT Impostazione del flusso continuo		

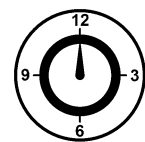
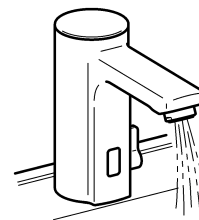
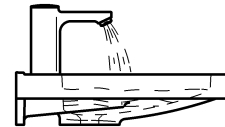
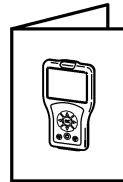
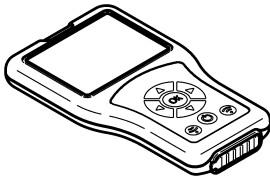
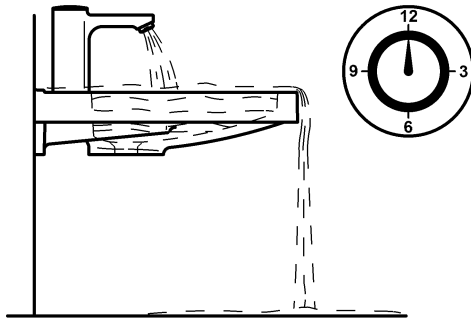
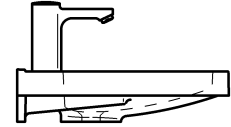

60 s

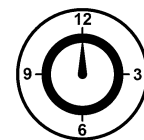
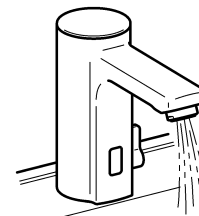
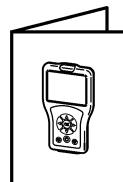
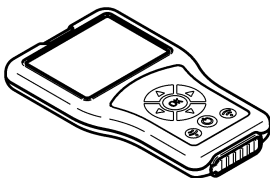

1 – 255 s

12. Reinigungsabschaltung einstellen

EN Adjusting the cleaning
switch-off

FR Régler l'arrêt du nettoyage

ES Ajuste de la desconexión de
limpieza

IT Impostazione dello spegnimento per pulizia

NL Reinigingsuitschakeling
instellen

PL Ustawianie funkcji wyłączenia
na czas czyszczenia

SV Ställa in rengörings
avstängning

CS Nastavení vypnutí za účelem čištění

FI Puhdistuskatkaisun säätäminen

RU Настройка отключения для очистки

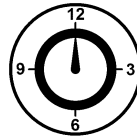
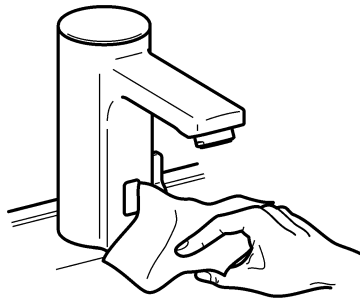

60 s

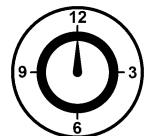
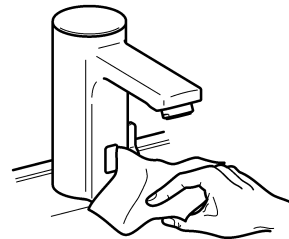
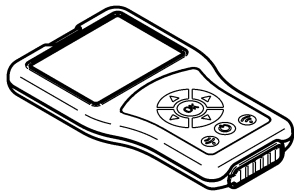

1 – 255 s

13. Temperaturanschlag einstellen

EN Setting the temperature stop

NL Temperatuurbegrenzing instellen

CS Nastavení teplotního limitu

FR Réglage de la butée de température

PL Ustawienie ograniczenia temperatury

FI Lämpötilarajoittimen säätäminen

ES Ajuste del tope de temperatura

SV Ställa in temperaturstoppet

RU Настройка температурного упора

IT Impostazione del blocco temperatura

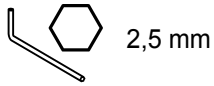

1

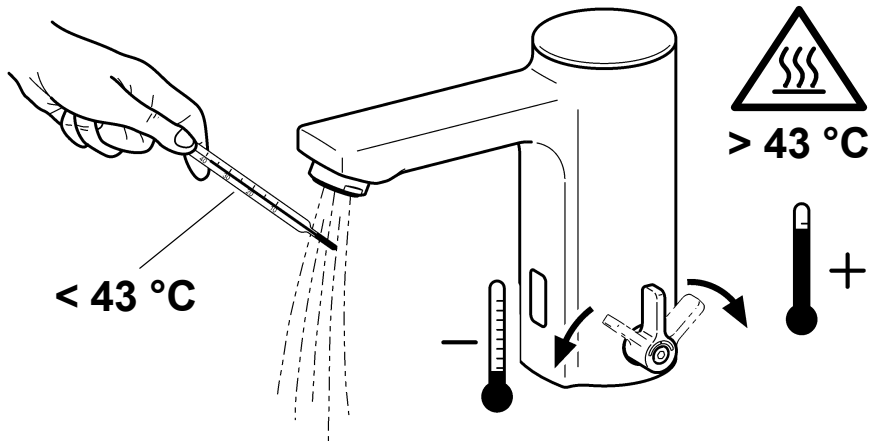

2

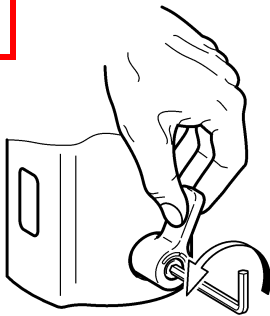

3

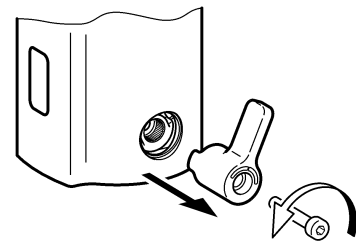

4

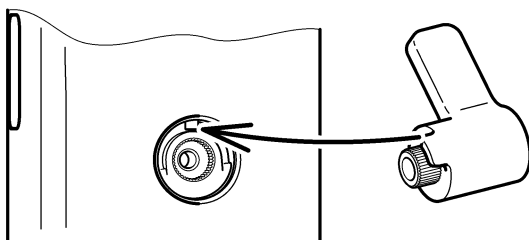

5

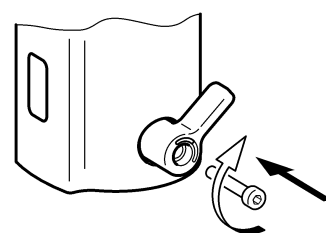

14. Wartung

EN Maintenance
FR Maintenance
ES Mantenimiento
IT Manutenzione

NL Onderhoud
PL Konserwacja
SV Underhåll

CS Varování
FI Huolto
RU Техническое обслуживание



 22 mm

1

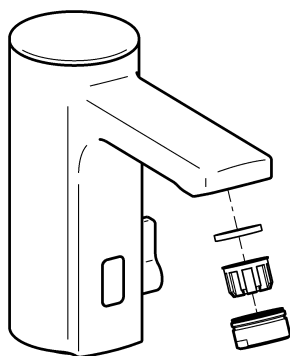

2

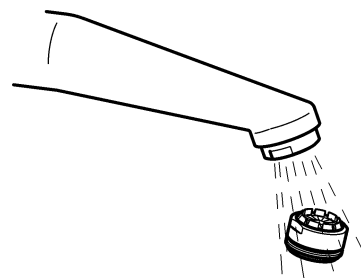

15. Siebe wechseln

EN Replace the filters

FR Remplacement les filtres

ES Cambiar los tamices

IT Sostituire i filtri

NL Zeven vervangen

PL Wymiana sit

SV Byt filter

CS Vyměňte síto

FI Siivilän vaihto

RU Сменить сеточки



 19 mm

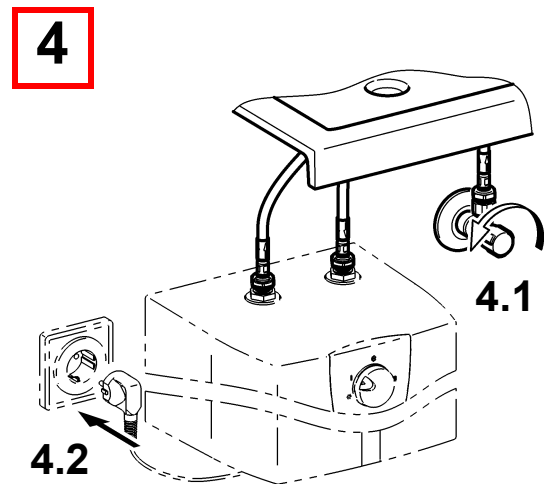
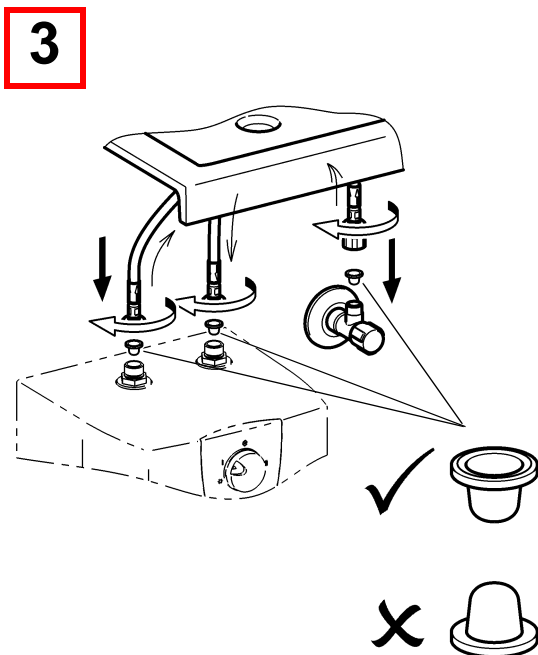
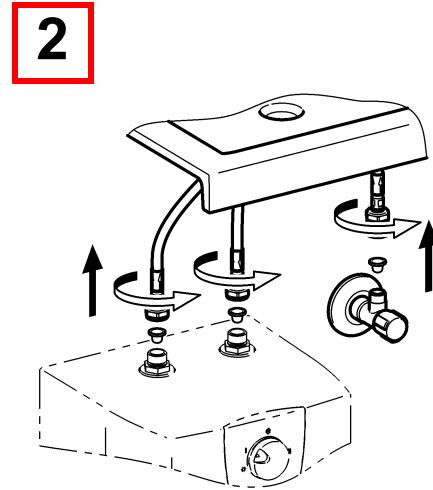
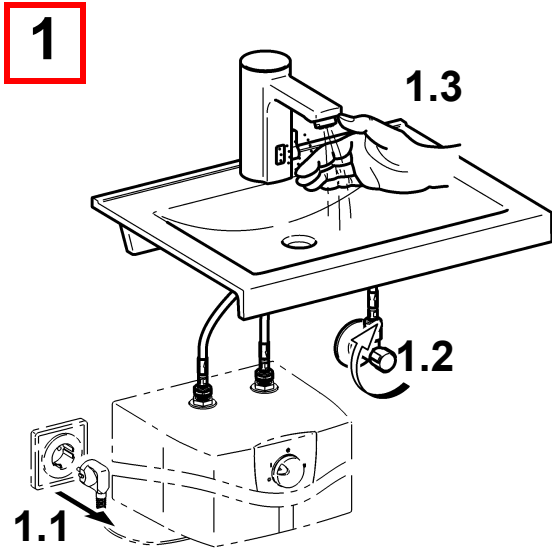

16. Magentventilkartusche wechseln

EN Replacing the solenoid valve cartridge	NL Magneetventielpatroon vervangen	CS Výměna kartuše magnetického ventilu
FR Remplacement de la cartouche de l'électrovanne	PL Wymiana wkładu zaworu elektromagnetycznego	FI Magneettiventtiilikasetin vaihto
ES Cambiar cartucho de la válvula electromagnética	SV Byta magnetventilpatron	RU Замена вставного электромагнитного клапана
IT Sostituzione della valvola elettromagnetica a cartuccia		

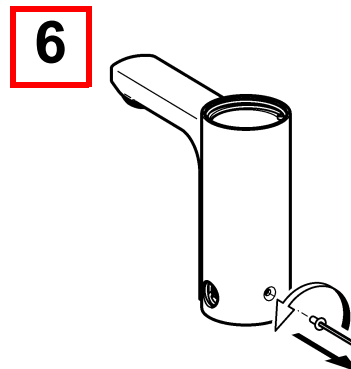
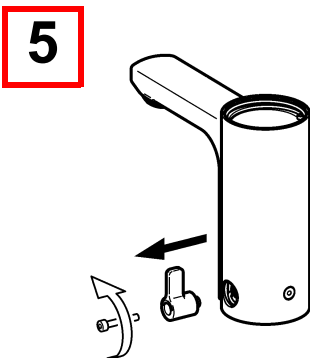
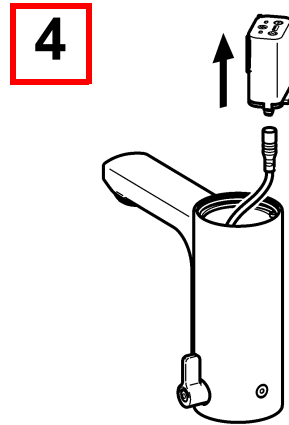
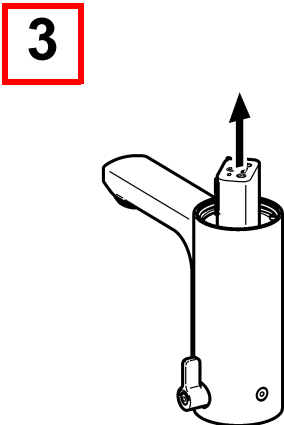
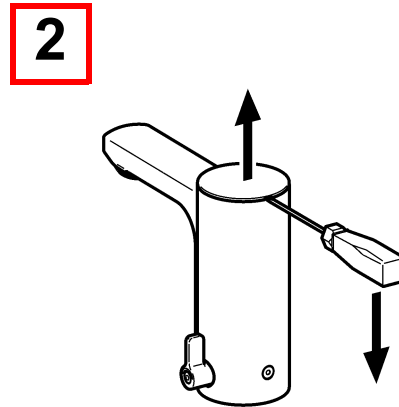
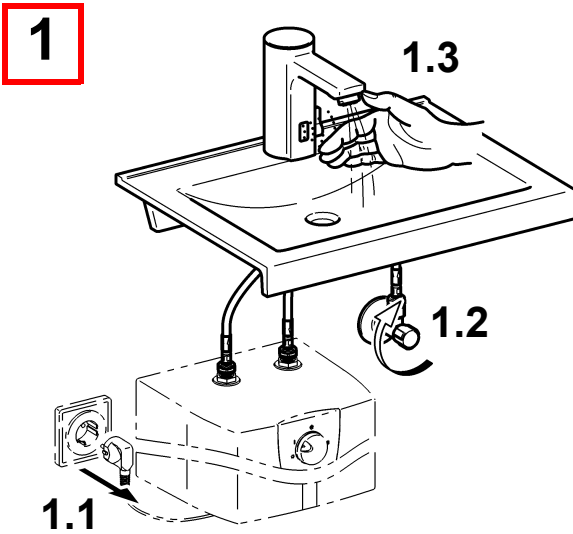
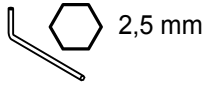

7

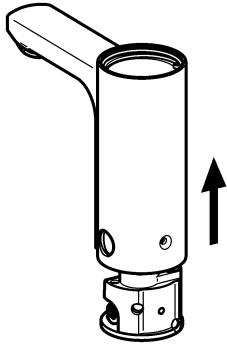

8

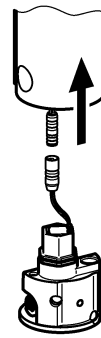

9

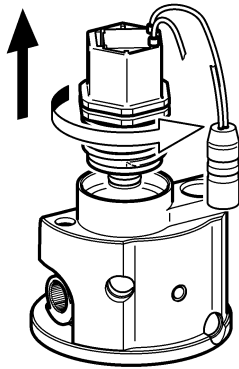

10

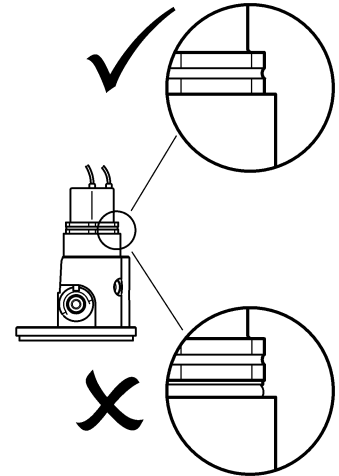
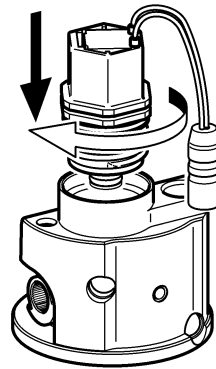

11



12

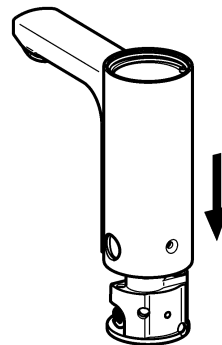

13

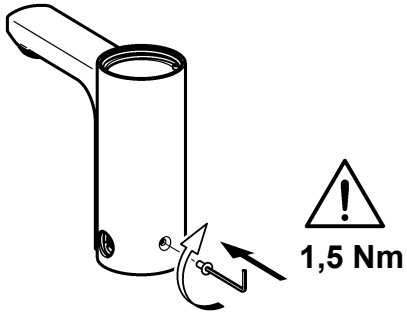

14

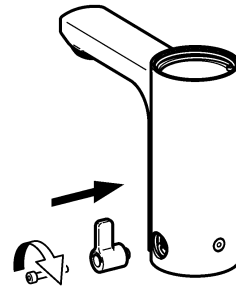

15

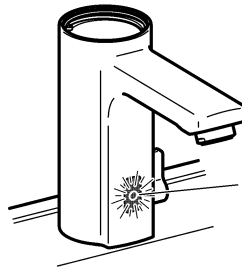
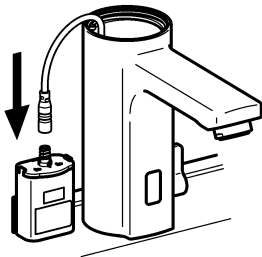

3.

A

B

16

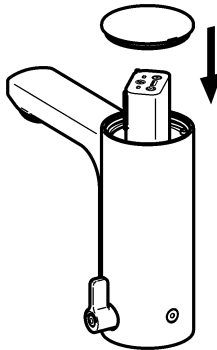

17

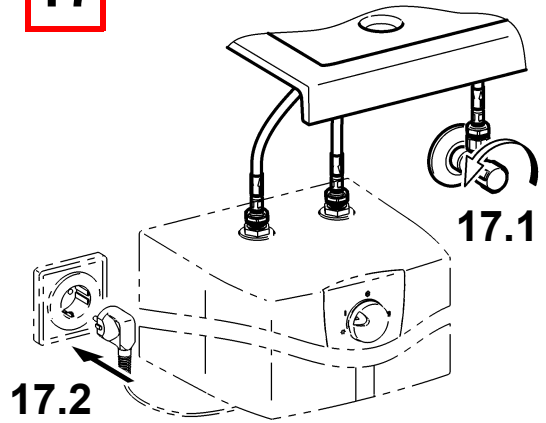

18



13.



> 43 °C

17. Durchflussmengenregler wechseln

EN Replace the flow rate regulator	NL Debietregelaar vervangen	CS Byt flödesregulator
FR Remplacement du régulateur de débit	PL Wymiana regulatora wielkości przepływu	FI Lämpivirtausmäärän säätimen vaihto
ES Cambiar el regulador volumétrico de paso	SV Byt flödesregulator	RU Заменить регулятор расхода
IT Sostituire il regolatore di portata		



 19 mm

1

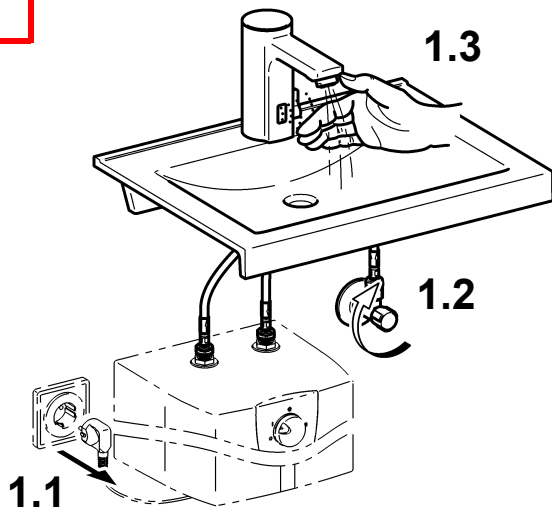

2

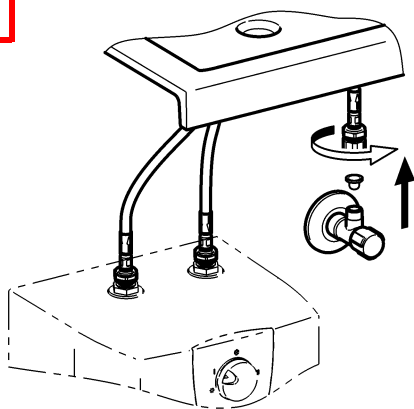

3

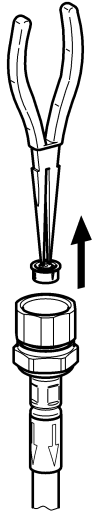

4

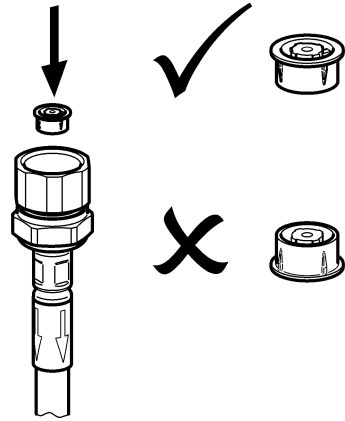

5

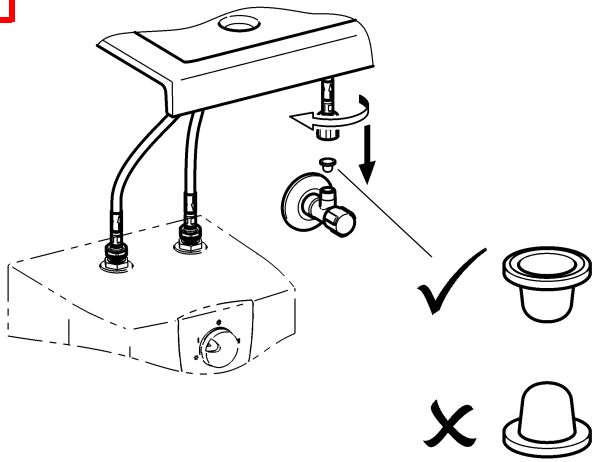

6

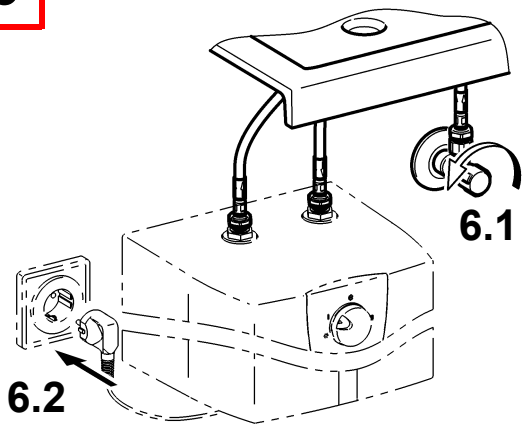

18. Batteriewechsel

EN Battery replacement
FR Remplacement des piles
ES Cambio de la pila
IT Cambio delle batterie

NL Batterijen vervangen
PL Wymiana baterii
SV Batteribyte

CS Výměna baterie
FI Paristonvaihto
RU замена батареи



4 mm

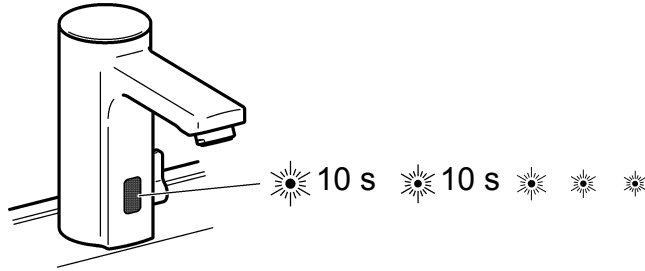

1

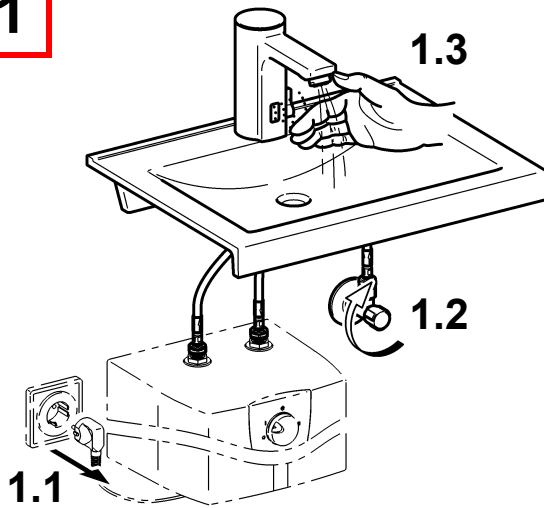

2

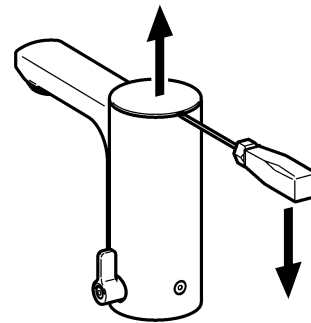

3

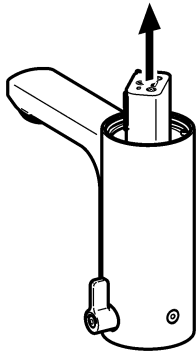

4

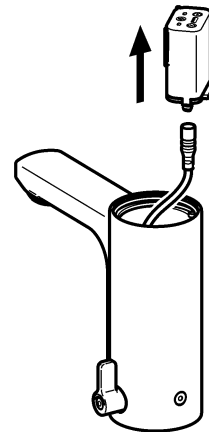

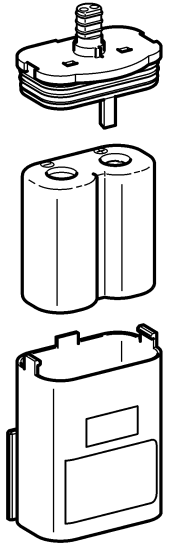

5

6 V DC

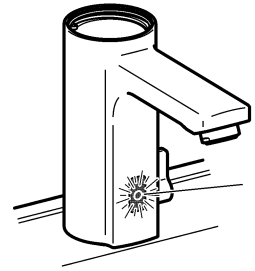
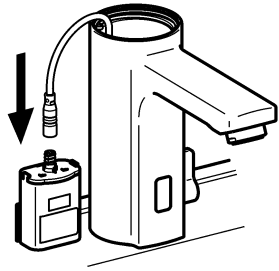

6



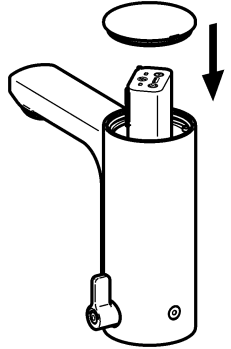

3.
A
B

7

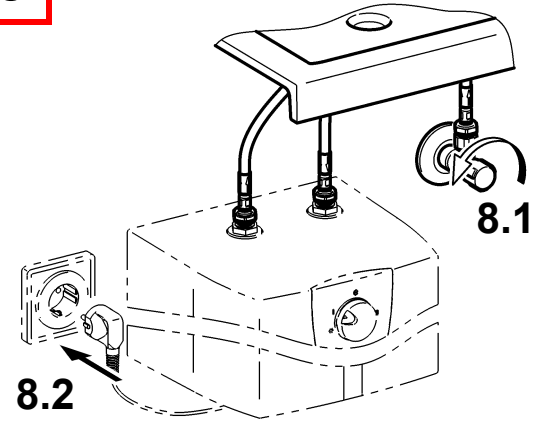

8



19. Mischeinrichtung verdecken

EN Conceal mixed-water facility

NL Menginrichting verbergen

CS Zakrýt míchací zařízení

FR Dispositif mélangeur

PL Zakryć urządzenie mieszające

FI Peitä miksauslaite

ES Cubrir el elemento mezclador

SV Dölj blandingsanordning

RU Закрыть смеситель так, чтобы его не было видно

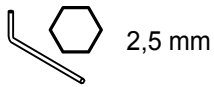

2,5 mm

1

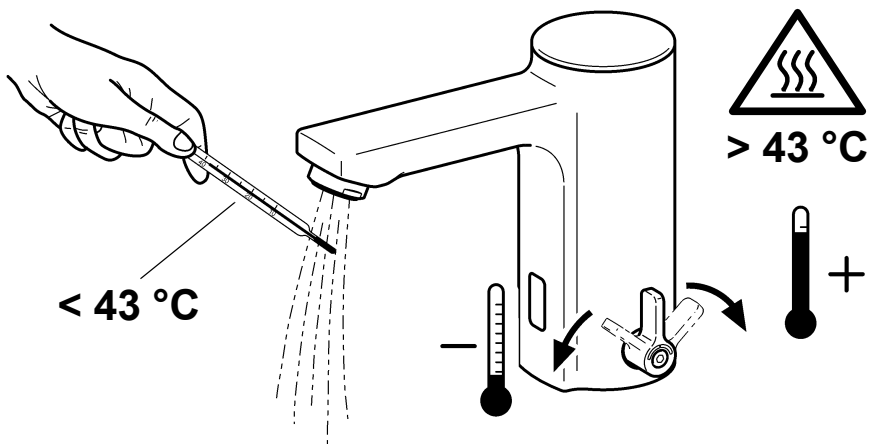

2

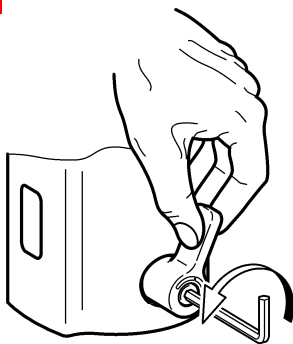

3

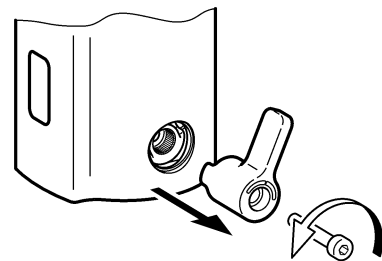

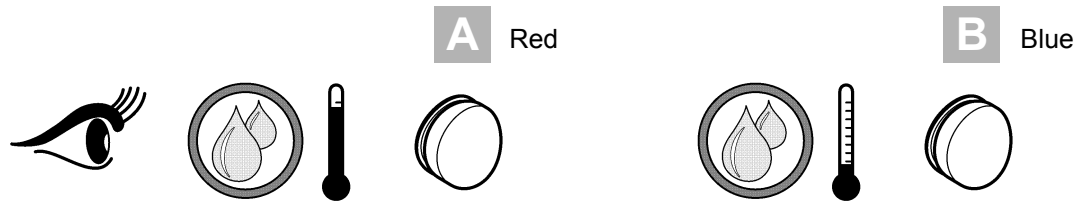

4

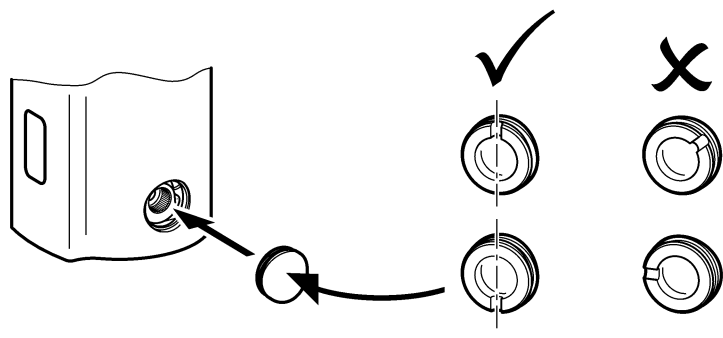

EN A Red
B Blue

ES A Rojo
B Azul

PL A Czerwony
B Niebieski

FI A Punainen
B Sininen

DE A Rot
B Blau

IT A Rosso
B Blu

SV A Röd
B Blå

RU A красный
B голубой

FR A Rouge
B Bleu

NL A Rood
B Blauw

CS A Červený
B Modrý

20. Ersatzteile

EN Replacement parts
FR Pièces de rechange
ES Piezas de recambio
IT Pezzi di ricambio

NL Reserveonderdelen
PL Części zamienne
SV Reservdelar

CS Náhradní díly
FI Varaosat
RU Запчасти

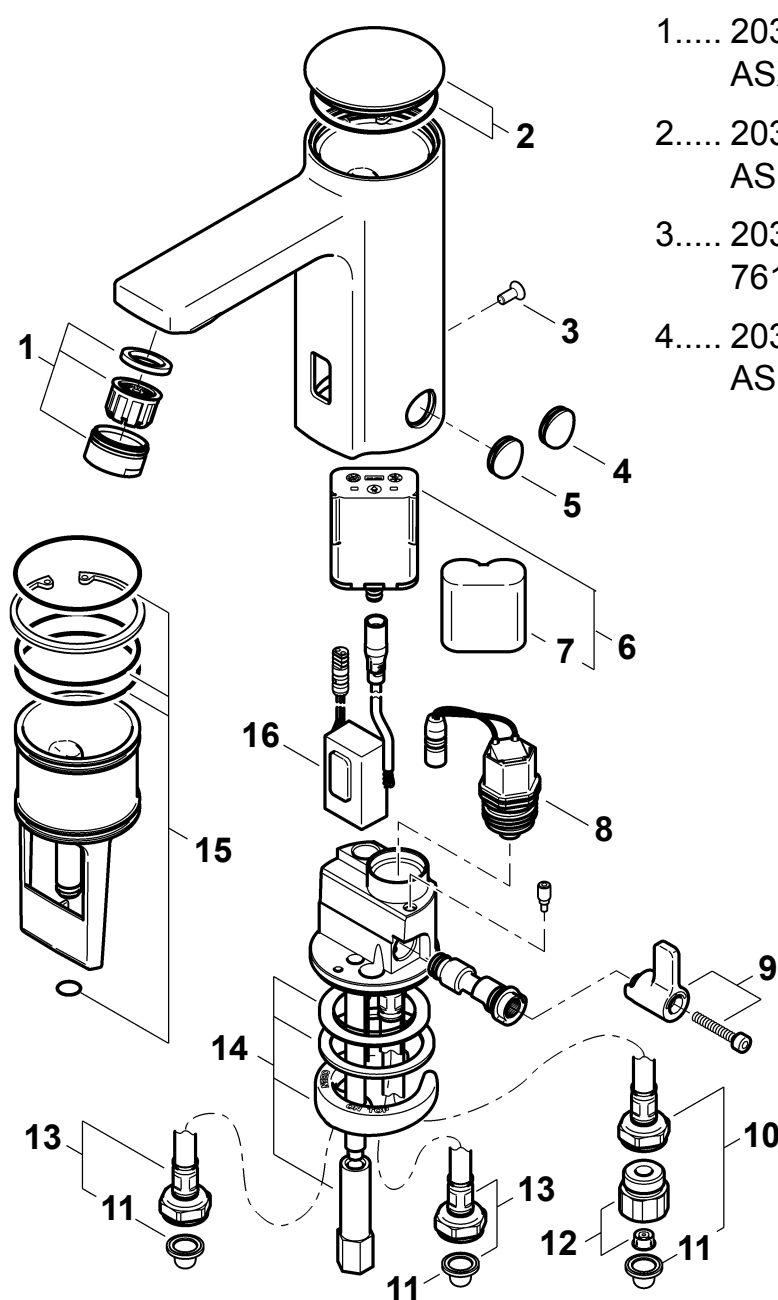

1..... 2030041424 a)	ASXX1008	5 ... 2030041952 a, c)	ASEX1010
2..... 2030041558	ASEX1007	6 ... 2000109466	ZAQCT0003
3..... 2030041947	7612982248801	7 ... 2000104846	EPTR0008
4..... 2030041951 a, b)	ASEX1009	8 ... 2030003033	EAQFU0001
		9 ... 2030041431	ASEM1001
		10 .. 380 mm:	
			2030041311
			ASXX1005
		11... 2000104720 a)	
			7612982129384
		12 .. 2000109480	
			7612982079153
		13 .. 520 mm:	
			2030041313
			ASXX1006
		14 .. 2030043596	
			ASEX1013
		15 .. 2030041949	
			ASEX1008
		16 .. 2030041458	
			ASEX1005

EN a) 10 pieces
b) Red
c) Blue

ES a) 10 piezas
b) Rojo
c) Azul

PL a) 10 sztuk
b) Czerwony
c) Niebieski

FI a) 10 kappaletta
b) Punainen
c) Sininen

DE a) 10 Stück
b) Rot
c) Blau

IT a) 10 pezzi
b) Rosso
c) Blu

SV a) 10 styck
b) Röd
c) Blå

RU a) 10 штук
b) красный
c) голубой

FR a) 10 pièces
b) Rouge
c) Bleu

NL a) 10 stuk
b) Rood
c) Blauw

CS a) 10 kusů
b) Červený
c) Modrý

21. Zubehör

EN Accessories
FR Accessoire
ES Accesorios
IT Accessori

NL Toebehoren
PL Akcesoria
SV Tillbehör

CS Příslušenství
FI Varusteet
RU принадлежности

1

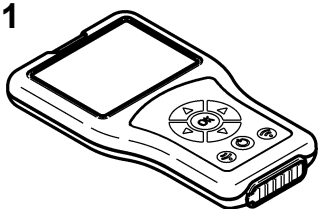

2



1..... 2030036654
ACEX9005

2..... 2030036849
ACEX9004

3..... 2000109145
ACXM1001

3

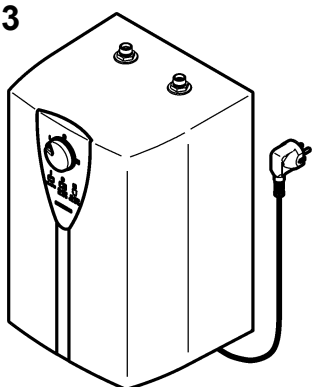

Australia

PR Kitchen and Water Systems Pty Ltd
Dandenong South VIC 3175
Phone +61 3 9700 9100

Austria

Franke GmbH
6971 Hard
Phone +43 5574 6735 0

Belgium & Luxembourg

Franke N.V.
9400 Ninove, Belgium
Phone +32 54 310 130

Czech Republic

Franke Aquarotter GmbH
14974 Ludwigsfelde, Germany
Phone +420 281 090 429

France

Franke GmbH
6971 Hard, Austria
Phone +33 800 909 216

Germany

Franke Aquarotter GmbH
14974 Ludwigsfelde
Phone +49 3378 818 530

Italy

Franke Water Systems AG
4663 Aarburg, Switzerland
Numero Verde 800 789 233

Middle East

Franke LLC
Ras Al Khaimah, United Arab Emirates
Phone +971 7 2034 700

Morocco

Franke Kitchen System SARL
21 000 Casablanca
Phone +212 522 674 200

Netherlands

Franke N.V.
9400 Ninove, Belgium
Phone +31 492 72 82 24

Poland

Franke Aquarotter GmbH
14974 Ludwigsfelde, Germany
Phone +48 22 711 6717

Portugal

Franke Portugal S.A.
2735-531 Cacém
Phone +351 21 426 9670

South Africa & Sub Saharan Africa

Franke South Africa
Durban, 4052
Phone + 27 31 450 6300

Spain

Franke GmbH
6971 Hard, Austria
Phone +43 5574 6735 211

Switzerland & Liechtenstein

Franke Water Systems AG
4663 Aarburg
Phone +41 62 787 3131

Turkey

Franke Mutfak ve Banyo Sistemleri
Sanayi ve Ticaret A.S.
41400 Gebze Kocaeli
Phone +90 262 644 6595

United Kingdom

Franke Sissons Ltd.
Barlborough S43 4PZ
Phone +44 1246 450 255

Dart Valley Systems Ltd.

Paignton TQ4 7TW
Phone +44 1803 529 021

EAST EUROPE

**Bosnia Herzegovina | Bulgaria |
Croatia | Hungary | Latvia | Lithuania |
Romania | Russia | Serbia | Slovakia |
Slovenia | Ukraine**

Franke Aquarotter GmbH
14974 Ludwigsfelde, Germany
Phone +49 3378 818 530

NORTH AMERICA

United States | Canada
Franke Kindred Canada Limited
Midland, ON L4R 4K9, Canada
Phone +1 855 446 5663

SCANDINAVIA & ESTONIA

**Finland | Sweden | Norway |
Denmark | Estonia**
Franke Finland Oy
76850 Naarjärvi, Finland
Phone +358 15 34 111

OTHER COUNTRIES

Franke GmbH
6971 Hard, Austria
Phone +43 5574 6735 0

