

F3

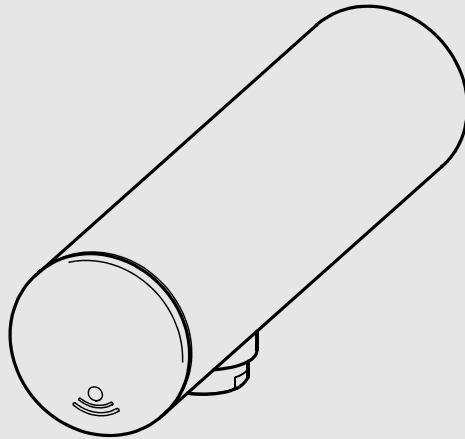

F3EV1004
2030036177
7612982238796

DE	Montage- und Betriebsanleitung	Elektronik-Wandventil
EN	Installation and operating instructions	Electronic bib tap
FR	Notice de montage et de mise en service	Vanne murale électronique
ES	Instrucciones de montaje y servicio	Válvula de pared con sistema electrónico
IT	Istruzioni per il montaggio e l'uso	Valvola da parete elettronica
NL	Montage- en bedrijsinstructies	Electronic bib tap
PL	Instrukcja montażu i obsługi	Elektroniczna bateria ścienna
SV	Monterings- och driftinstruktion	
CS	Návod pro montáž a provoz	
FI	Asennus- ja käyttöohje	Elektroninen seinäventtiili
RU	Инструкция по монтажу и вводу в эксплуатацию	

*Make
it
Wonderful*

FRANKE

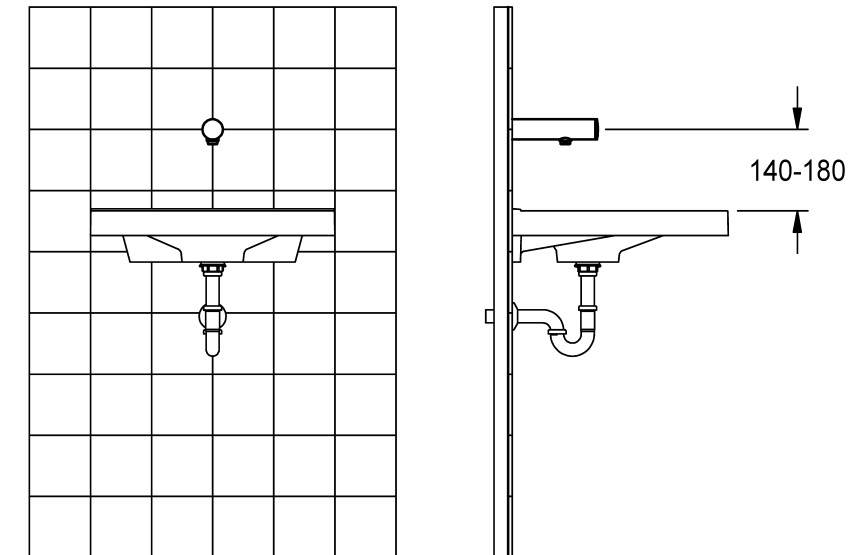
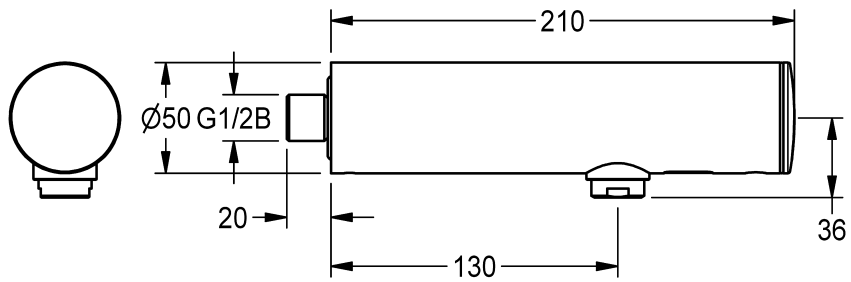
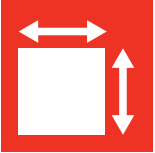
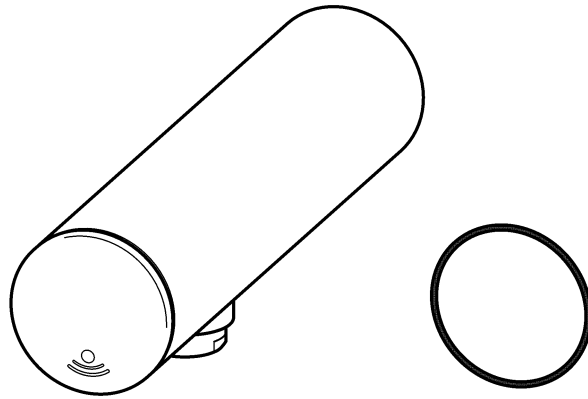

EN

Installation and operating instructions

Important notes

- ▶ Before installing flush piping system!
- ▶ The fitting must be operated only with original mesh filters!
- ▶ The fitting must be checked and maintained at regular intervals depending on the water quality and in accordance with the local conditions, and rules and regulations applicable at the site.
- ▶ Install a revisable sieve on site.

Technical data

- ▶ Minimum flow pressure 1.0 bar
- ▶ Maximum operating pressure 10 bar
- ▶ Recommended flow pressure 1-5 bar
- ▶ Volume flow at 3 bar flow pressure 6 l/min
- ▶ maximum operating temperature
 - continuous operation 70 °C
 - short-term (<10 min) 80 °C
- ▶ Voltage supply with lithium battery CRP2 6 V DC
- ▶ Power consumption 1,5 W
- ▶ Type of protection IP 59K

PL

Instrukcja montażu i obsługi

Ważne wskazówki

- ▶ Przed instalacją przepłukać rury!
- ▶ Armatury należy używać wyłącznie z oryginalnymi sitkami!
- ▶ Armaturę należy poddawać regularnej kontroli i konserwacji w zależności od jakości wody, warunków lokalnych i obowiązujących przepisów.
- ▶ Zainstalować sitko nadające się do kontroli.

Dane techniczne

- ▶ Minimalne ciśnienie przepływu 1,0 bar
- ▶ Maksymalne ciśnienie robocze 10 barów
- ▶ Zalecane ciśnienie przepływu 1-5 barów
- ▶ Objętościowe natężenie przepływu przy ciśnieniu 3 barów 6 l/min
- ▶ Maksymalna temperatura eksploatacji
 - Praca stała 70 °C
 - Czas krótki (<10 min) 80 °C
- ▶ Zasilanie elektryczne baterią litową CRP2 6 V DC
- ▶ Pobór mocy 1,5 W
- ▶ Rodzaj ochrony IP 59K

DE

Montage- und Betriebsanleitung

Wichtige Hinweise

- ▶ Vor Installation Rohrleitungen spülen!
- ▶ Armatur nur mit original Sieb betreiben!
- ▶ In Abhängigkeit von der Wasserqualität, den örtlichen Gegebenheiten und den vor Ort geltenden Bestimmungen die Armatur in regelmäßigen Abständen prüfen und warten.
- ▶ Bauseits ein revisionsfähiges Sieb installieren.

Technische Daten

- ▶ Mindestfließdruck 1,0 bar
- ▶ Maximaler Betriebsdruck 10 bar
- ▶ Empfohlener Fließdruck 1-5 bar
- ▶ Volumenstrom bei 3 bar Fließdruck 6 l/min
- ▶ maximale Betriebstemperatur
 - Dauerbetrieb 70 °C
 - Kurzzeit (<10 min) 80 °C
- ▶ Spannungsversorgung
Lithium Batterie CRP2 6 V DC
- ▶ Leistungsaufnahme 1,5 W
- ▶ Schutzart IP 59K

SV

Monterings- och driftinstruktion

Viktiga informationer

- ▶ Spola igenom rörledningarna före installation!
- ▶ Använd armaturen endast med originalsilar!
- ▶ Kontrollera och serva armaturen med intervaller som bestäms av vattenkvaliteten samt de lokala förhållandena och de bestämmelser som gäller där.
- ▶ Installera en kontrollerbar sil på monteringsplatsen.

Tekniska data

- ▶ Minsta hydrauliska tryck 1,0 bar
- ▶ Maximalt driftryck 10 bar
- ▶ Rekommenderat hydrauliskt tryck 1-5 bar
- ▶ Volymström vid 3 bar hydrauliskt tryck 6 l/min
- ▶ Maximal driftstemperatur
 - Kontinuerlig drift 70 °C
 - Kort tid (< 10 min) 80 °C
- ▶ Spänningsförsörjning med litiumbatteri CRP2 6 V DC
- ▶ Effektbehov 1,5 W
- ▶ Skyddsklass IP 59K

FR

Notice de montage et de mise en service

Remarques importantes

- ▶ Rincer les conduites avant d'installer !
- ▶ Ne faire fonctionner la robinetterie qu'avec les filtres d'origine !
- ▶ En fonction de la qualité de l'eau, ainsi que des conditions et des dispositions locales, il convient de contrôler et d'entretenir la robinetterie à intervalles réguliers.
- ▶ Le client doit installer un filtre pouvant faire l'objet d'une révision.

Données techniques

- ▶ Pression dynamique minimale 1,0 bar
- ▶ Pression de service maximale 10 bars
- ▶ Pression dynamique recommandée 1-5 bars
- ▶ Débit volumique pour 3 bars de pression dynamique 6 l/min
- ▶ Température de fonctionnement maximale
 - Fonctionnement continu 70 °C
 - Courte période (< 10 min) 80 °C
- ▶ Alimentation en tension avec pile au lithium CRP2 6 V DC
- ▶ Puissance absorbée 1,5 W
- ▶ Type de protection IP 59K

ES

Instrucciones de montaje y servicio

Indicaciones importantes

- ▶ ¡Enjuagar las tuberías antes de instalar!
- ▶ ¡La grifería debe hacerse funcionar únicamente con los tamices originales!
- ▶ En función de la calidad del agua, las condiciones locales y la legislación vigente, realizar las inspecciones y el mantenimiento de la grifería a intervalos regulares.
- ▶ El cliente debe instalar un filtro inspeccionable.

Datos técnicos

- ▶ Presión mínima de flujo 1,0 bar
- ▶ Presión máxima de servicio 10 bares
- ▶ Presión de flujo recomendada 1-5 bares
- ▶ Flujo volumétrico con 3 bares de presión de flujo 6 l/min
- ▶ Temperatura de servicio máxima
 - Funcionamiento continuo 70 °C
 - Tiempo breve (< 10 min) 80 °C
- ▶ Alimentación de corriente con batería de litio CRP2 6 V DC
- ▶ Consumo de potencia 1,5 W
- ▶ Modo de protección IP 59K

CS

Návod pro montáž a provoz

Důležité pokyny

- ▶ Před instalací potrubí propláchněte!
- ▶ Provozovat armaturu jen s originálními sítky!
- ▶ V závislosti na kvalitě vody, místních podmínkách a předpisech platných v místě instalace je nutné provádět v pravidelných intervalech kontrolu a údržbu armatury.
- ▶ Na místě instalace nainstalujte reverzní sítko.

Technické údaje

- ▶ Minimální průtočný tlak 1,0 bar
- ▶ Maximální provozní tlak 10 bar
- ▶ Doporučený průtočný tlak 1-5 bar
- ▶ Průtok při průtočném tlaku 3 bar 6 l/min
- ▶ Maximální provozní teplota
 - Doba provozu 70 °C
 - Krátký čas (< 10 min.) 80 °C
- ▶ Napájení lithiovou baterií CRP2 6 V DC
- ▶ Příkon 1,5 W
- ▶ Krytí IP 59K

FI

Asennus- ja käyttöohje

Tärkeitä ohjeita

- ▶ Huhuhtelee putkijohdot ennen asennusta!
- ▶ Käytä Lisävarusteet vain alkuperäisten sihtien!
- ▶ Hana tulee tarkistaa ja huoltaa säännöllisin väliajoin veden laadusta, paikallisista oloista ja paikalla voimassa olevista määräyksistä riippuen.
- ▶ Asenna rakennukseen puhdistettavissa oleva sihti.

Tekniset tiedot

- ▶ Vähimmäisvirtauspaine 1,0 bar
- ▶ Suurin käyttöpaine 10 bar
- ▶ Suositeltava virtauspaine 1-5 bar
- ▶ Tilavuusvirta 3 barin virtauspaineella 6 l/min
- ▶ Maksimaalinen käyttölämpötila
 - Jatkuva käyttö 70 °C
 - Lyhyt aika (<10 min) 80 °C
- ▶ Jännitteensyöttö litiumparistolla CRP2 6 V DC
- ▶ Tehonkulutus 1,5 W
- ▶ Suojaustapa IP 59K

IT

Istruzioni per il montaggio e l'uso

Avvertenze importanti

- ▶ Sciacquare le tubazioni prima di installare!
- ▶ Utilizzare la rubinetteria esclusivamente con i filtri originali!
- ▶ Controllare e sottoporre a manutenzione l'apparecchio ad intervalli regolari, in funzione della qualità dell'acqua, delle caratteristiche locali e delle vigenti disposizioni locali.
- ▶ Installare in loco un filtro ispezionabile.

Specifiche tecniche

- ▶ Pressione idraulica min. 1,0 bar
- ▶ Pressione di esercizio max. 10 bar
- ▶ Pressione idraulica consigliata 1-5 bar
- ▶ Portata volumetrica a 3 bar di pressione idraulica 6 l/min
- ▶ Temperatura massima di esercizio
 - Funzionamento continuo 70 °C
 - Brevemente (<10 min) 80 °C
- ▶ Alimentazione di tensione con batteria al litio CRP 2 di 6 V DC
- ▶ Potenza assorbita 1,5 W
- ▶ Tipo di protezione IP 59K

NL

Montage- en bedrijfsinstructies

Belangrijke aanwijzingen

- ▶ Voor installatie buisleidingen spoelen!
- ▶ Armatuur alleen met originele zeven gebruiken!
- ▶ Afhankelijk van de waterkwaliteit, de plaatselijke omstandigheden en de plaatselijke voorschriften de armatuur regelmatig controleren en onderhouden.
- ▶ Monteer op de bouwlocatie een vervangbare zeef.

Technische gegevens

- ▶ Minimale dynamische druk 1,0 bar
- ▶ Maximale werkdruk 10 bar
- ▶ Aanbevolen dynamische druk 1-5 bar
- ▶ Volumestroom bij 3 bar dynamische druk 6 l/min
- ▶ Maximale bedrijfstemperatuur
 - Continubedrijf 70 °C
 - Kortstondig (<10 min) 80 °C
- ▶ Spanningsvoorziening d.m.v. lithiumbatterij CRP2 6 V DC
- ▶ Opgenomen vermogen 1,5 W
- ▶ Veiligheidsgraad IP 59K

RU

Инструкция по монтажу и вводу в эксплуатацию

Важные указания

- ▶ Перед инсталляцией промыть трубки!
- ▶ Эксплуатировать арматуру только с оригинальными фильтрами!
- ▶ Арматуру необходимо регулярно чистить и обслуживать в зависимости от качества воды, местных условий и действующих в месте эксплуатации предписаний.
- ▶ Установку сетки с доступом для осмотра обеспечить заказчику.

Технические характеристики

- ▶ Минимальный гидравлический напор 1,0 бар
- ▶ Максимальное рабочее давление 10 бар
- ▶ Рекомендуемый гидравлический напор 1-5 бар
- ▶ Объёмный расход при гидравлическом напоре 3 бар 6 л/мин
- ▶ Максимальная рабочая температура
 - Непрерывный режим работы 70 °C
 - Короткое время (<10 мин) 80 °C
- ▶ Источник питания - литиевая батарея CRP 2 6 В постоянного тока
- ▶ Потребляемая мощность 1,5 Вт
- ▶ Вид защиты IP 59K

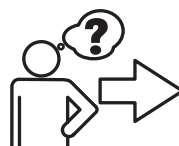
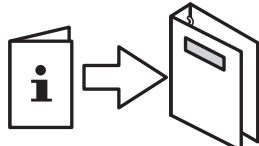
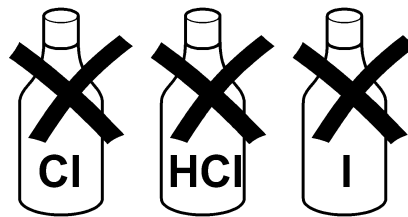
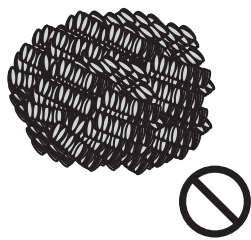

www.franke.com

1. Montage

EN Installation
 FR Montage
 ES Montaje
 IT Montaggio

NL Montage
 PL Montaż
 SV Montering

CS Montáž
 FI Asennus
 RU Монтаж

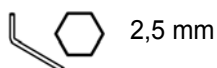

1

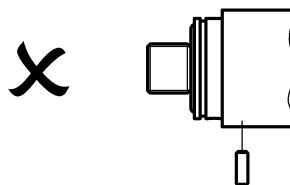
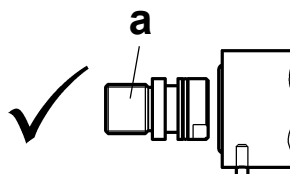
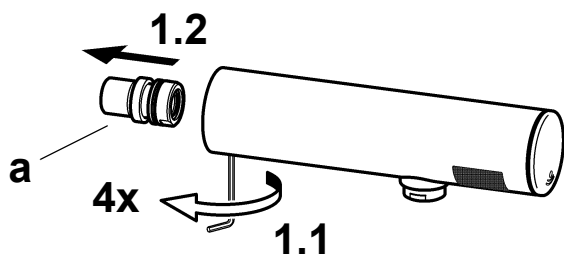

2

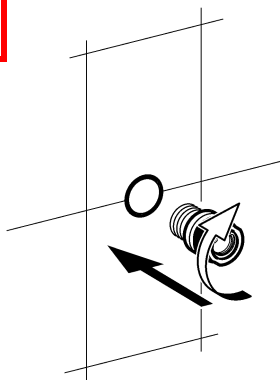

3

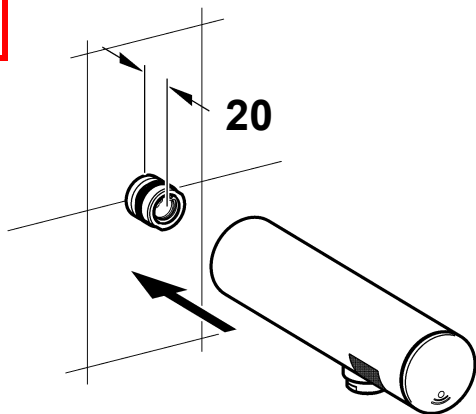

4

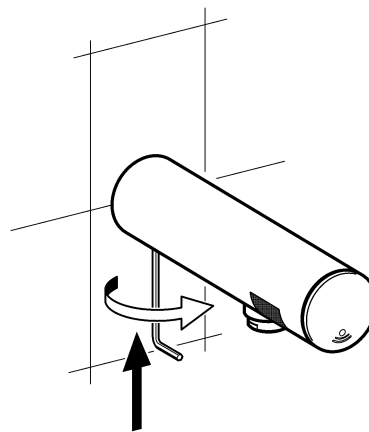

5

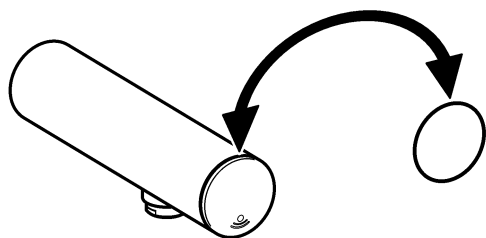

I Red

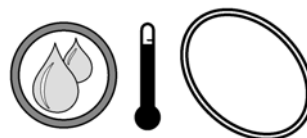

II Blue

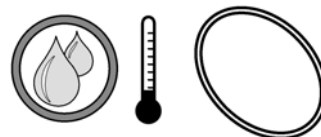

EN | Red
II Blue

ES | Rojo
II Azul

PL | Czerwony
II Niebieski

FI | Punainen
II Sininen

DE | Rot
II Blau

IT | Rosso
II Blu

SV | Röd
II Blå

RU | красный
II голубой

FR | Rouge
II Bleu

NL | Rood
II Blauw

CS | Červený
II Modrý

6

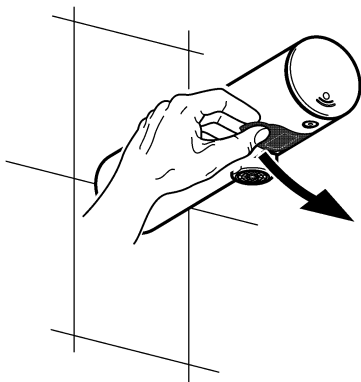

7

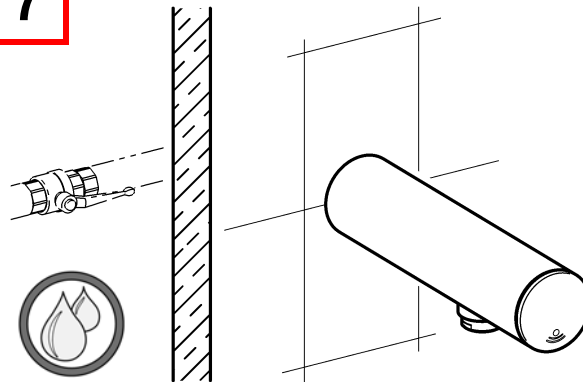

2. Funktion

EN Function

FR Fonctionnement

ES Función

IT Funzionamento

NL Werking

PL Funkcja

SV Funktion

CS Funkce

FI Toiminto

RU Функционирование

1



2

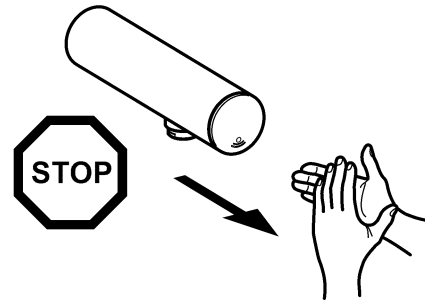

3. Hygienespülung ein- / ausschalten

EN Switching hygiene flushing on/off

FR Activer/désactiver le rinçage hygiénique

ES Activar/Desactivar el higiene enjuague

IT Attivare/disattivare lo igiene risciacquo

NL Hygiënische spoeling in-/uitschakelen

PL Włączyć/wyłączyć spłukiwanie higieniczne

SV Koppla hygienespolningen till / från

CS Zapněte/vypněte hygienické propláchnutí

FI Hygieniahuuhdelun päälle-/ pois päältä kytkeminen

RU Гигиеническое промывание включить/выключить

EN

- ▶ Ensure open outlet.
- ▶ After 24h of non-use, water flows 30 s.

DE

- ▶ Freien Auslauf gewährleisten.
- ▶ Nach 24h Nichtbenutzung fließt 30 s Wasser.

FR

- ▶ Garantir un écoulement libre.
- ▶ L'eau s'écoule pendant 30 s. après 24h de non utilisation.

ES

- ▶ Garantizar una salida libre.
- ▶ Si no se realiza ningún uso durante 24 horas, fluye agua durante 30 seg.

IT

- ▶ Garantire l'erogazione libera.
- ▶ Dopo 24h di inutilizzo scorre acqua per 30 s.

NL

- ▶ Vrije uitloop garanderen.
- ▶ Na 24 uur niet te zijn gebruikt stroomt er gedurende 30 s. water.

PL

- ▶ Zapewnić swobodny wylot.
- ▶ Po 24 godz. niekorzystania przez 30 s. wypływa woda.

SV

- ▶ Garantera fritt avlopp.
- ▶ Vatten flyter 30 s efter 24 timmars användningspaus.

CS

- ▶ Zajistěte volný odtok.
- ▶ Při nepoužívání 24 h nechte 30 s téct vodu.

FI

- ▶ Vapaa virtauksen takaaminen.
- ▶ Käyttämättömänä 24 h jälkeen virtaa vettä 30 s.

RU

- ▶ Обеспечить беспрепятственный слив
- ▶ После того, как устройство не используется в течение 24 ч, в течение 30 сек течёт вода.

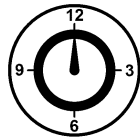
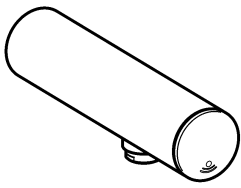

24 h

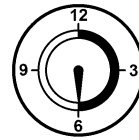
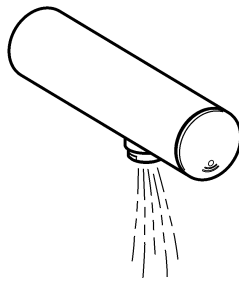

30 s

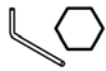
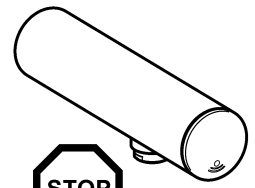

2,5 mm

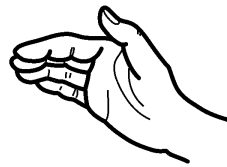

3.

1

-

12

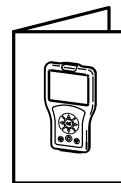
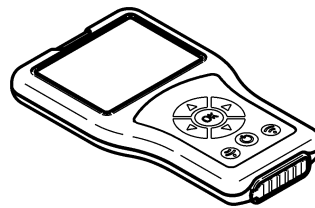
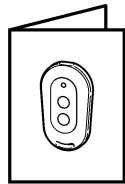
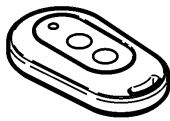

1

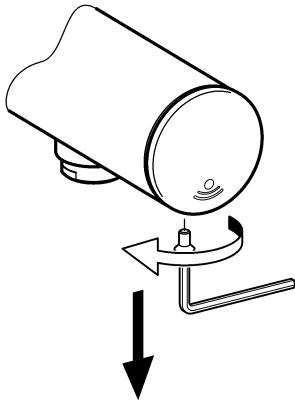

2

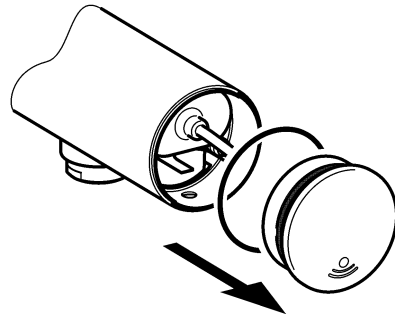

3

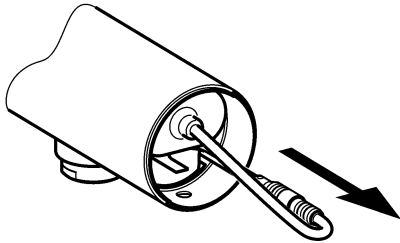

4

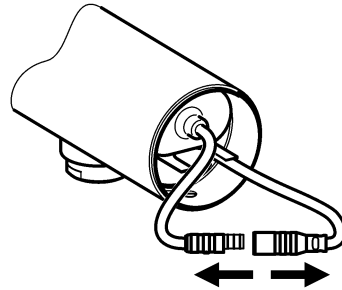

5

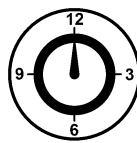

60 s

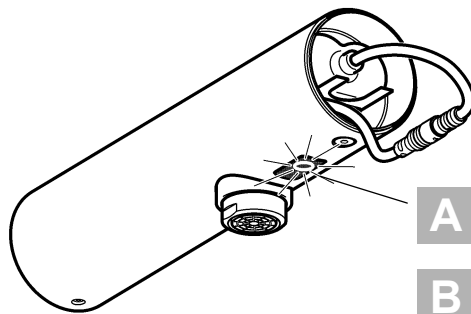
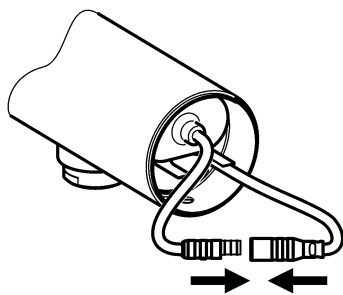

A 2x    

B 1x    

A

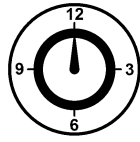
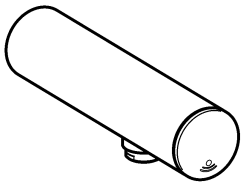

24 h

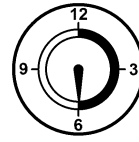
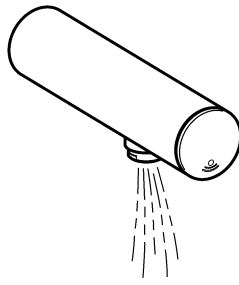

30 s

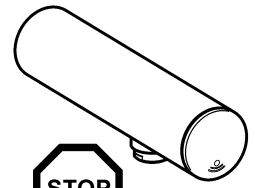

B

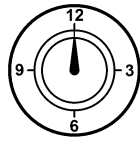
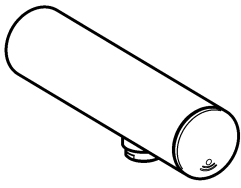

0 h

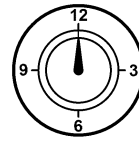
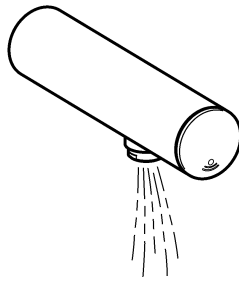

0 s

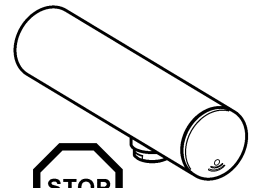

6

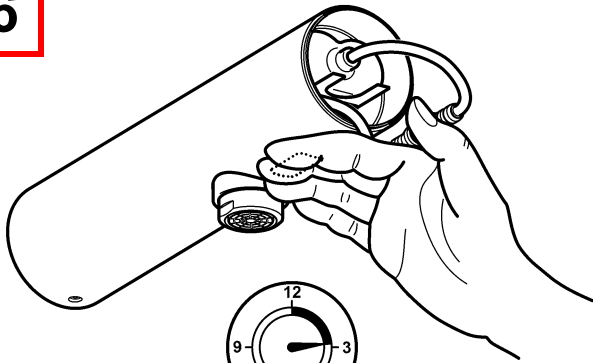

>12 s

7

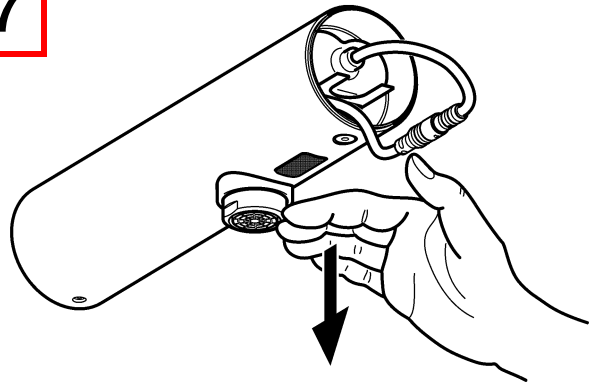

8

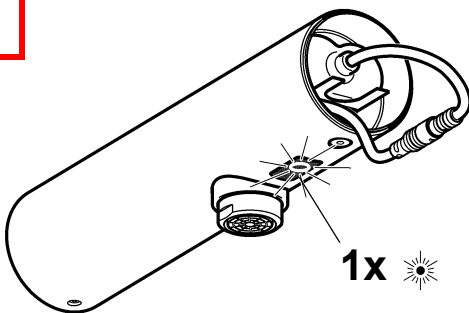

1x ✨

9

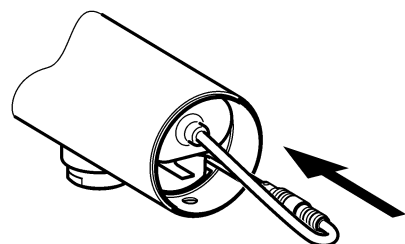

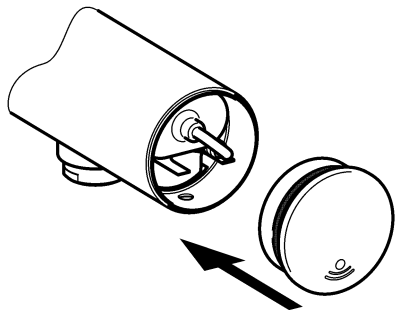
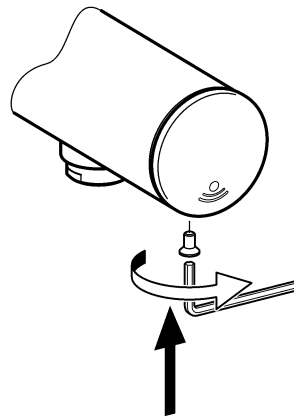
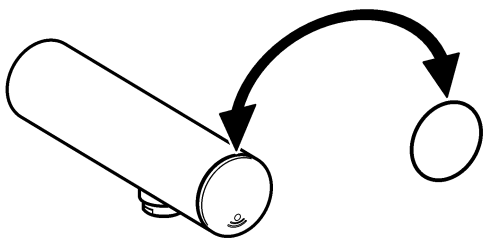
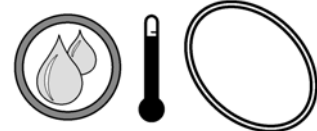
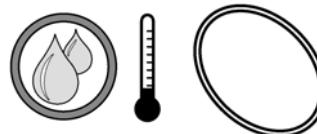
10**11****12****I** Red**II** Blue

EN | Red
II Blue

ES | Rojo
II Azul

PL | Czerwony
II Niebieski

FI | Punainen
II Sininen

DE | Rot
II Blau

IT | Rosso
II Blu

SV | Röd
II Blå

RU | красный
II голубой

FR | Rouge
II Bleu

NL | Rood
II Blauw

CS | Červený
II Modrý

4. Armatur ausschalten

EN Switch off the valve

NL Armatuur uitschakelen

CS Vypnout armaturu

FR Désactiver la robinetterie de

PL Wyłączenie baterii

FI Hanan kytkeminen pois päältä

ES Desconectar la grifería

SV Avstängning av armatur

RU Выключение смесителя

IT Disattivazione della rubinetteria

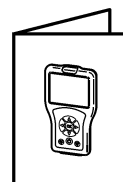
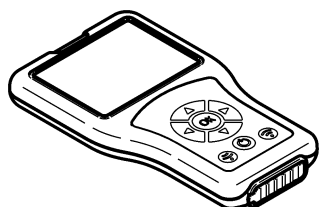

5. Dauerlauf starten

EN Start continual flow

NL Continue stroming starten

CS Spustit trvalý provoz

FR Démarrer la marche continue

PL Uruchomić stały wypływ wody

FI Tuotantokäytön aloittaminen

ES Iniciar el enjuague continuo

SV Starta kontinuerlig drift

RU запустить ресурс

IT Avviare l'erogazione continua

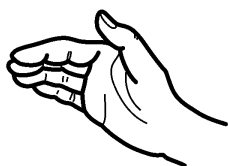

5.

1

2

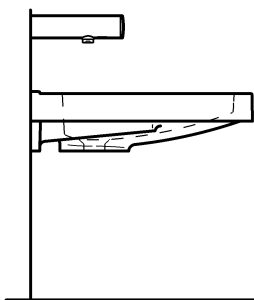
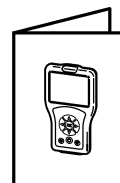
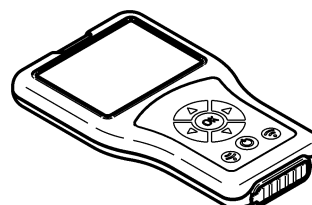

9.

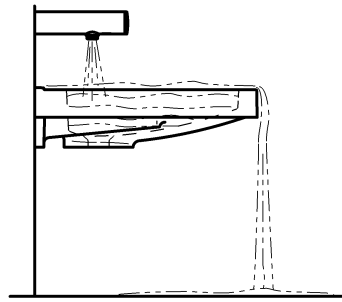

9.

1

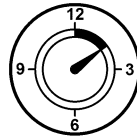
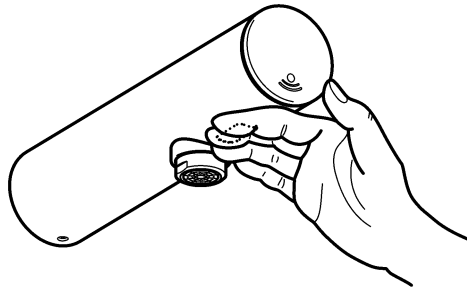

5 - 8 s

2

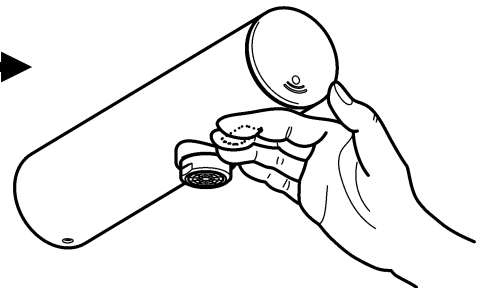
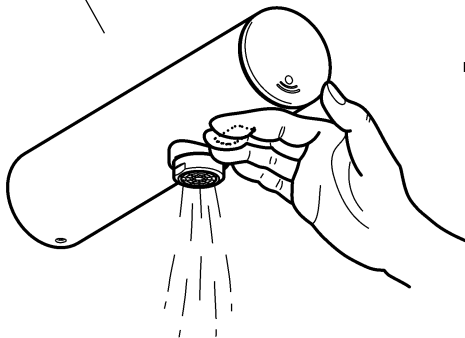
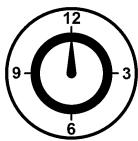
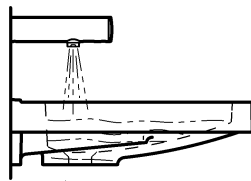
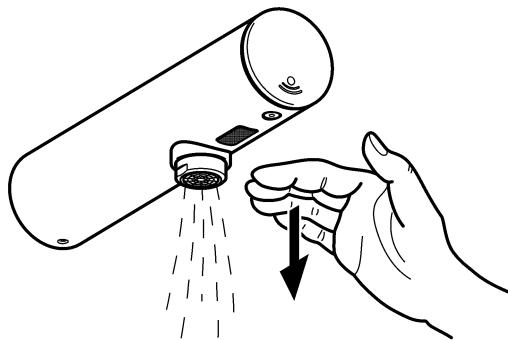

6. Reinigungsabschaltung einschalten

EN Switch on cleaning switch-off	NL Inschakelen van de reiniging shutdown	CS Vypínač pro čištění
FR Activer l'arrêt de nettoyage	PL Włączanie wyłączenia na czas czyszczenia	FI Aktivoida pesuseisokkien
ES Activar el apagado de limpieza	SV Aktivera rengörings avstängning	RU активировать чистка завершение работы
IT Attivare dello spegnimento per pulizia		

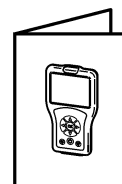
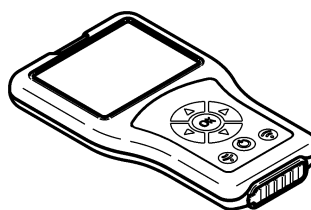
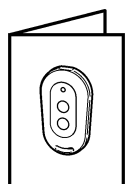
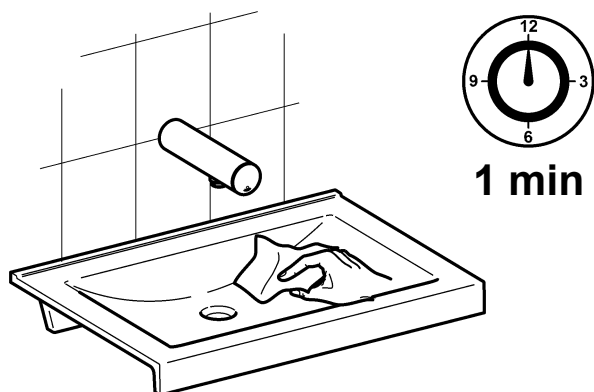

7. Reichweite einstellen

EN Adjusting the range

FR Réglage de la portée

ES Ajuste del alcance

IT Impostazione della portata

NL Actieradius instellen

PL Ustawienie zasięgu

SV Ställa in räckvidden

CS Nastavení dosahu

FI Tunnistusetäisyyden säätäminen

RU Настройка дальности действия

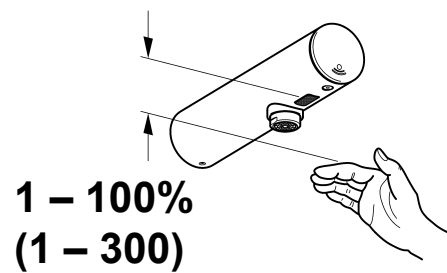
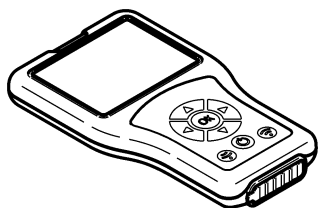
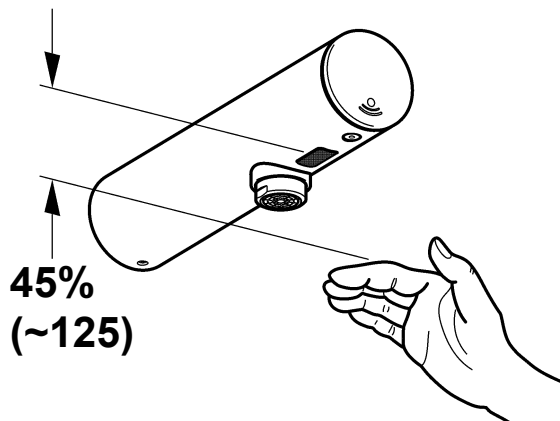

8. Hygienespülung einstellen

EN Setting the hygiene flush	NL Instellen van de hygiënespoeling	CS Nastavení hygienického proplachování
FR Réglage de la rinçage d'hygiène	PL Ustawianie spłukiwania higienicznego	FI Hygieniahuuhtelun säätäminen
ES Ajuste del higiene enjuague	SV Ställa in hygienspolning	RU установив гигиена смыва
IT Impostare lo igiene risciacquo		

- EN**
- ▶ I: Interval adjustable in h
 - ▶ II: Flow duration adjustable in s
- DE**
- ▶ I: Intervall einstellbar in h
 - ▶ II: Fließzeit einstellbar in s
- FR**
- ▶ I: intervalle réglable en h
 - ▶ II: durée d'écoulement réglable en s
- ES**
- ▶ I: Intervalo ajustable en horas
 - ▶ II: Tiempo de flujo activable en seg
- IT**
- ▶ I: intervallo impostabile in h
 - ▶ II: durata di flusso impostabile in s
- NL**
- ▶ I: Interval instelbaar in u
 - ▶ II: Stromingstijd instelbaar in s
- PL**
- ▶ I: odstęp czasu regulowany w godzinach
 - ▶ II: czas przepływu regulowany w sekundach
- SV**
- ▶ I: Intervall kan ställas in i timmar
 - ▶ II: Flödestid kan ställas in i sekunder
- CS**
- ▶ I: Interval s nastavením v h
 - ▶ II: Doba průtoku s nastavením v s
- FI**
- ▶ I: Aikaväli, asetettavissa h
 - ▶ II: Virtausaika, asetettavissa s
- RU**
- ▶ I: интервал задается в ч
 - ▶ II: время течения задается в сек.

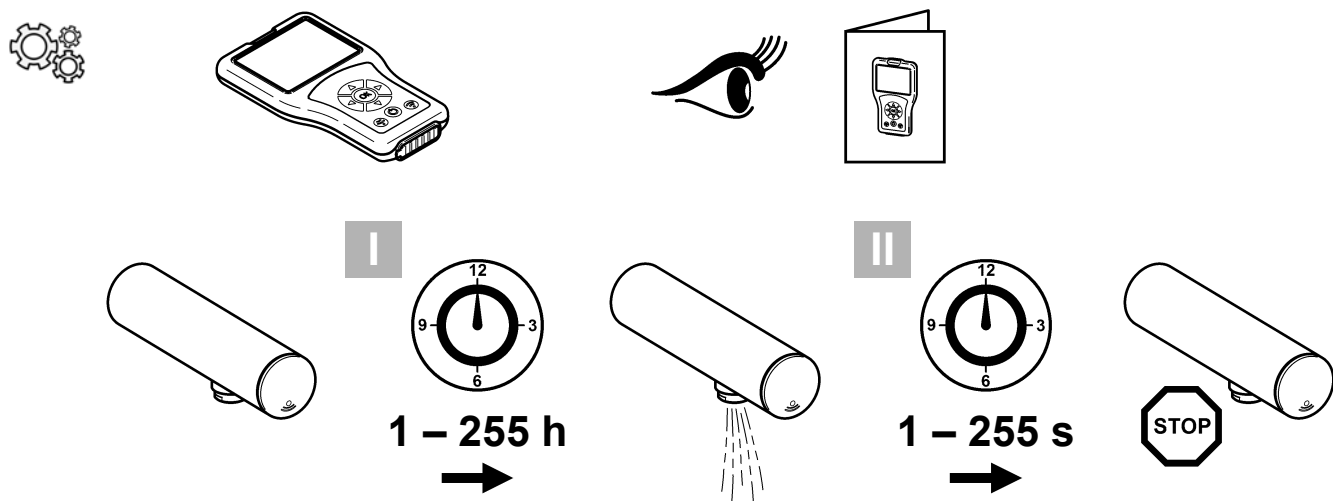
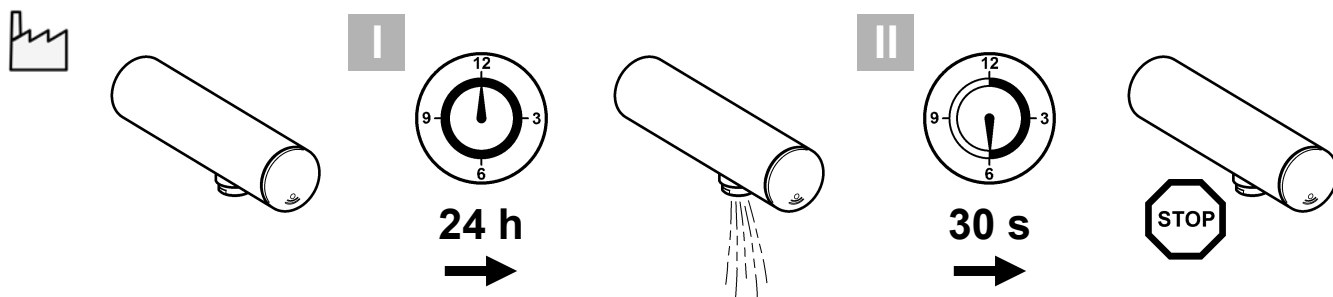

9. Dauerlauf einstellen

EN Setting continuous operating mode

NL Continue stroming instellen

CS Nastavení pomalejšího toku

FR Réglage du fonctionnement en continu

PL Ustawienie ciągłego wypływu

FI Tuotantokäytön säätäminen

ES Ajuste del funcionamiento ininterrumpido

SV Ställa in permanent flöde

RU Настройка непрерывного режима

IT Impostazione del flusso continuo

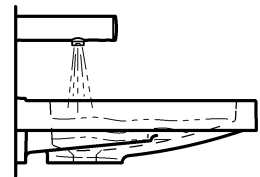
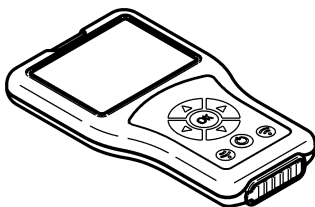
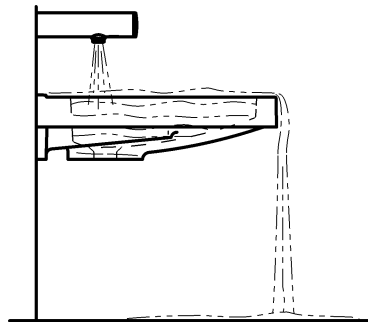
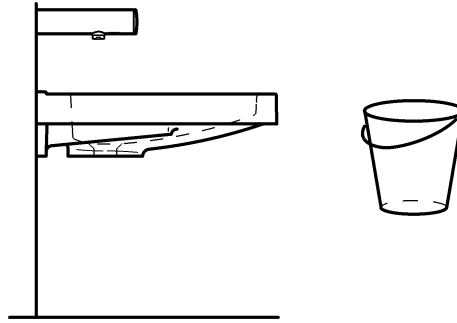

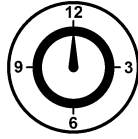
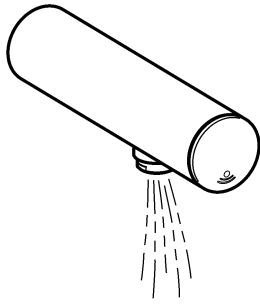

60 s

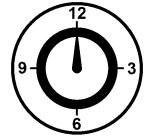
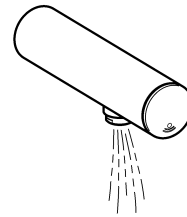
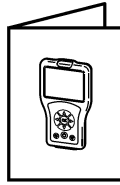
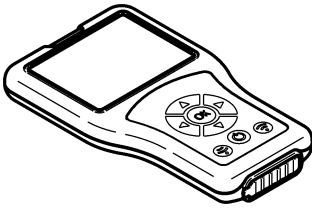

1 – 255s

10. Reinigungsabschaltung einstellen

EN Adjusting the cleaning switch-off

FR Régler l'arrêt du nettoyage

ES Ajuste de la desconexión de limpieza

IT Impostazione dello spegnimento per pulizia

NL Reinigungsuitschakeling instellen

PL Ustawianie funkcji wyłączenia na czas czyszczenia

SV Ställa in rengörings avstängning

CS Nastavení vypnutí za účelem čištění

FI Puhdistuskatkaisun säätäminen

RU Настройка отключения для очистки

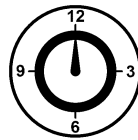
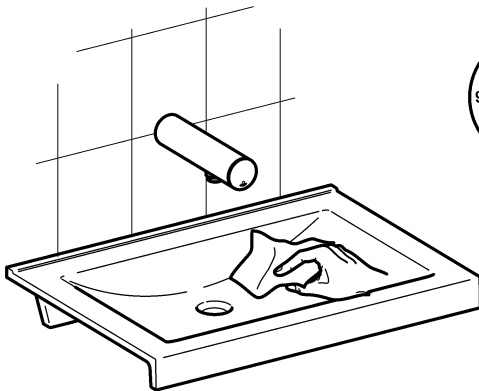

1 min

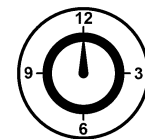
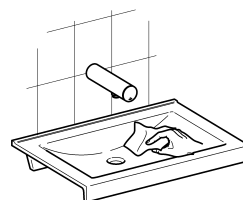
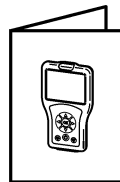
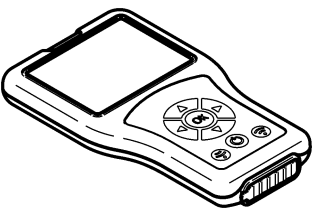

1 – 255min

11. Wartung

EN Maintenance
FR Maintenance
ES Mantenimiento
IT Manutenzione

NL Onderhoud
PL Konserwacja
SV Underhåll

CS Varování
FI Huolto
RU Техническое обслуживание



 22 mm

1

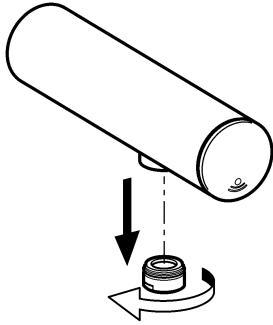

2

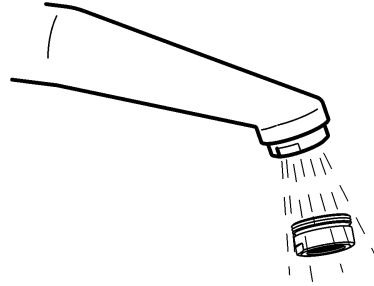

12.

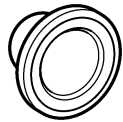

13.

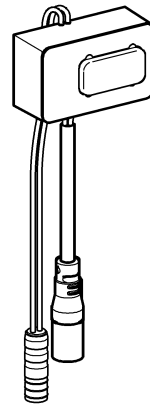

14.

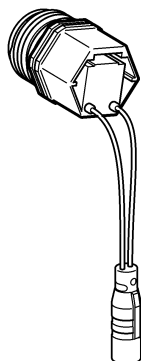

15.

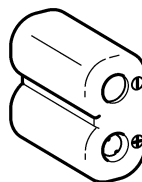

12. Sieb wechseln

EN Replace the filters
 FR Remplacement les filtres
 ES Cambiar los tamices
 IT Sostituire i filtri

NL Zeven vervangen
 PL Wymiana sit
 SV Byt filter

CS Vyměňte síto
 FI Siivilän vaihto
 RU Сменить сеточки

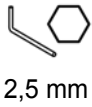

1

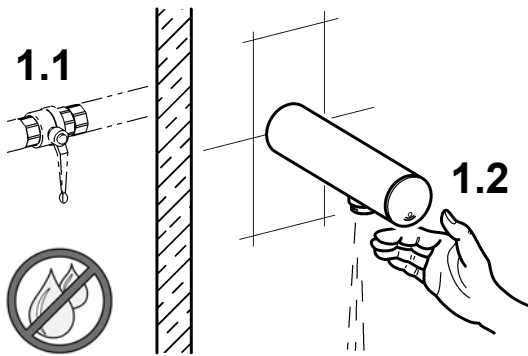

2

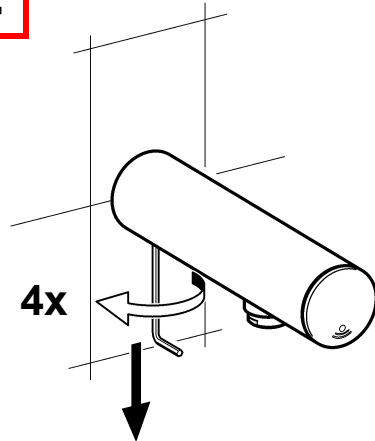

3

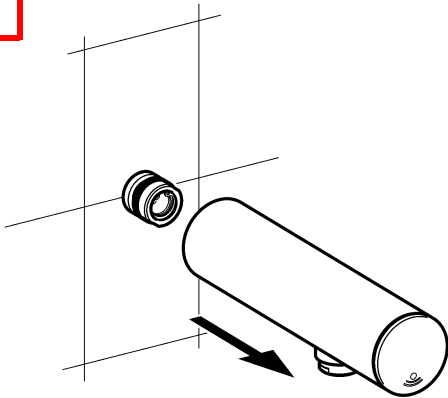

4

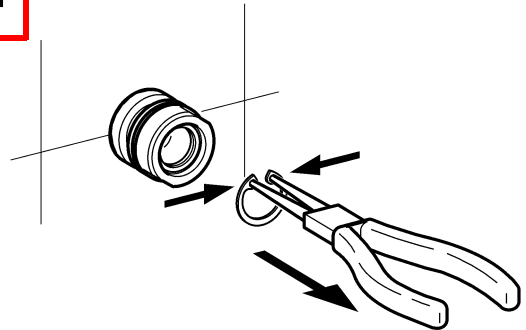

5

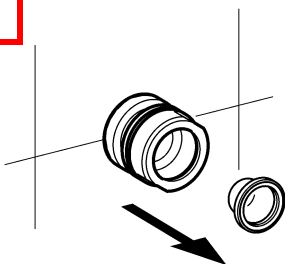

6

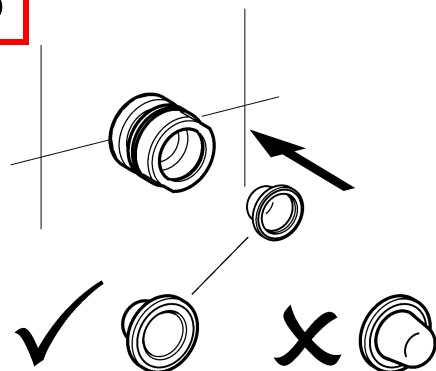

7

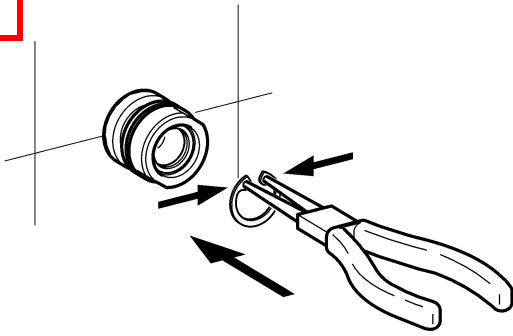

8

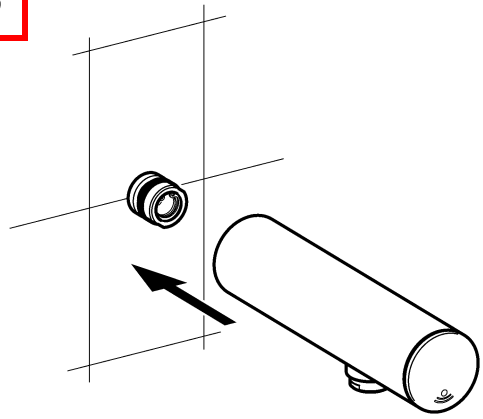

9

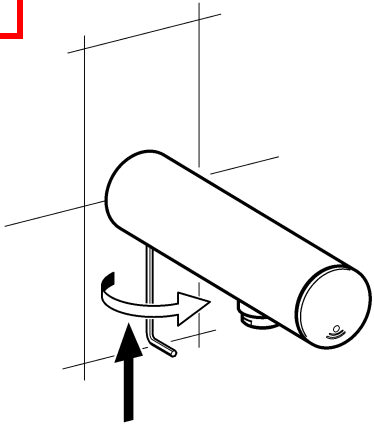

10

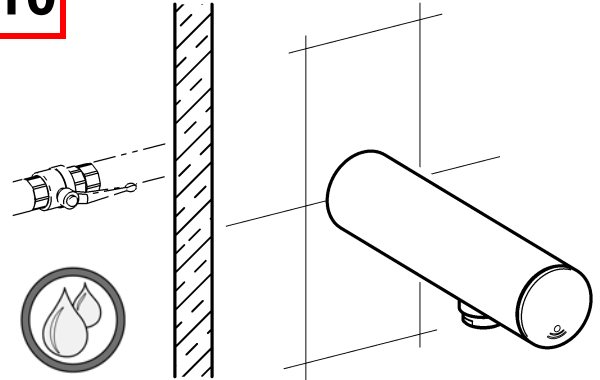

13. Sensor wechseln

EN Replace sensor
FR Changer le capteur
ES Cambiar el sensor
IT Cambiare il sensore

NL Sensor vervangen
PL Wymienić czujnik
SV Byt sensor

CS Vyměňte snímač
FI Anturi vaihto
RU Замена Датчик

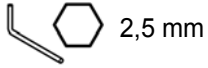

22 mm



1

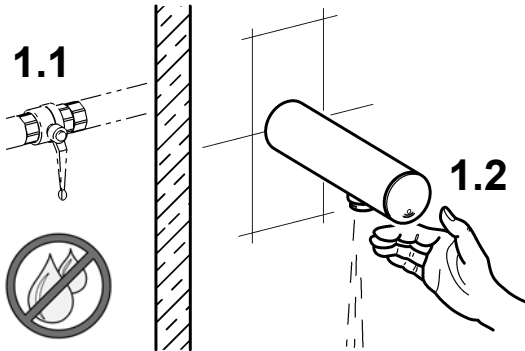

2

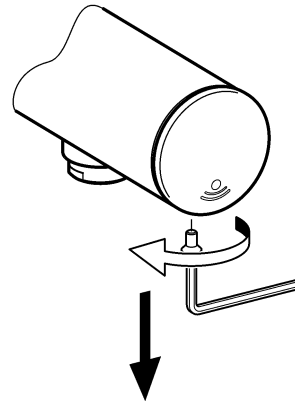

3

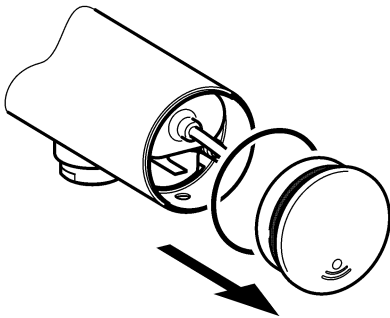

4

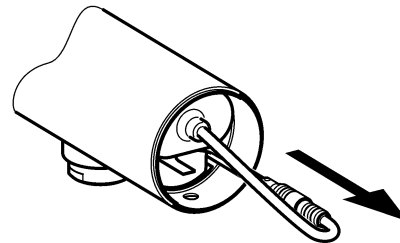

5

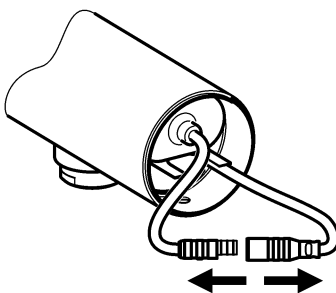

6

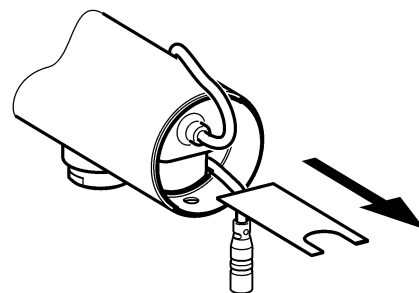

7

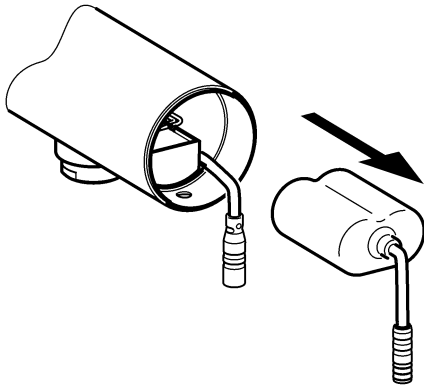

8

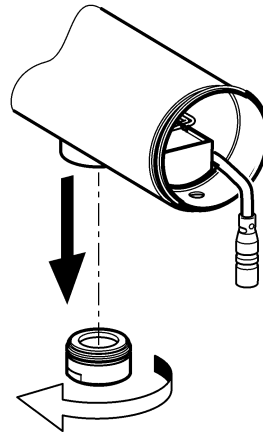

9

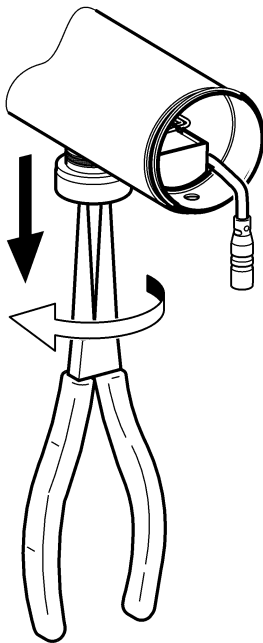

10

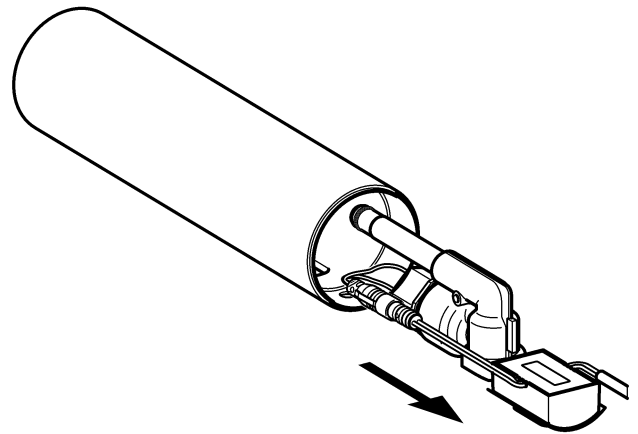

11

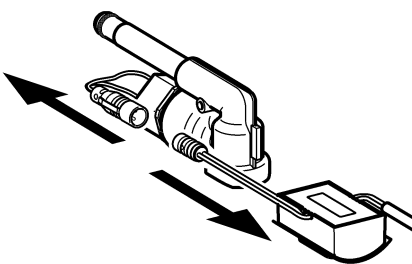

12

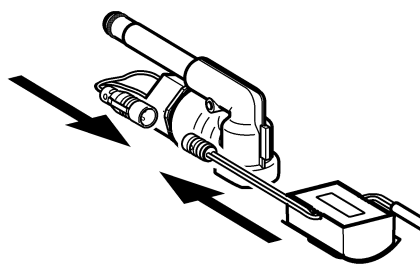

13

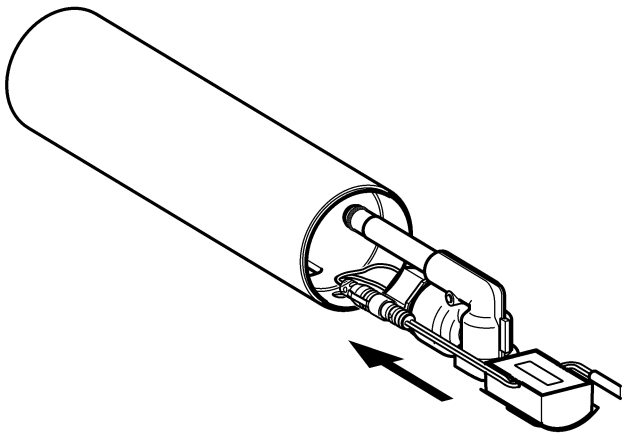

14

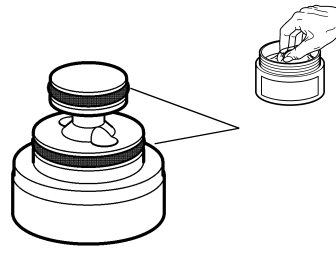

15

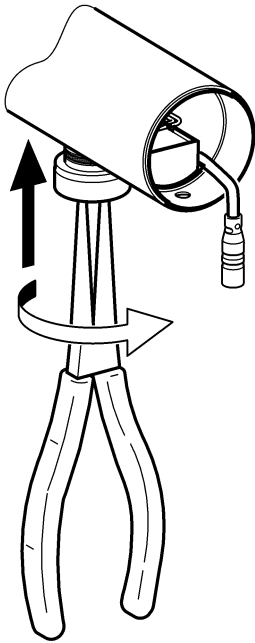

16

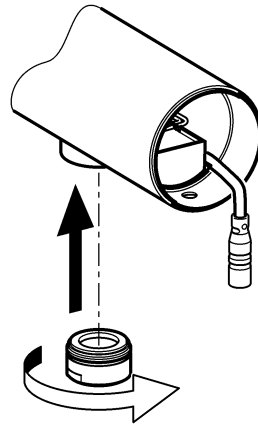

17

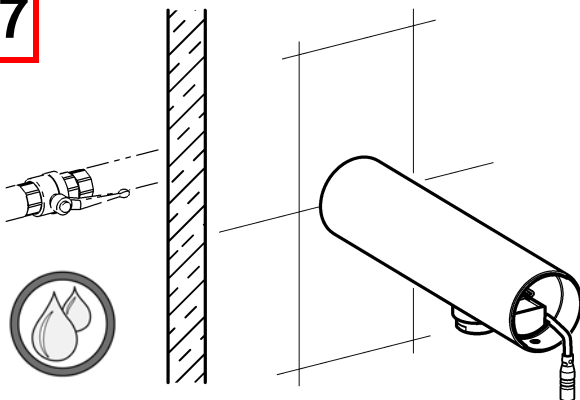



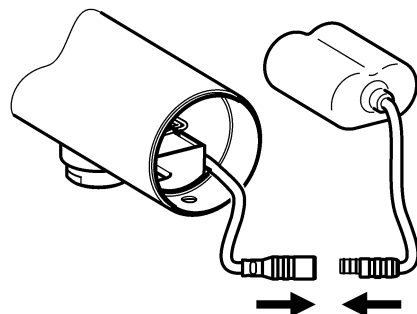

18

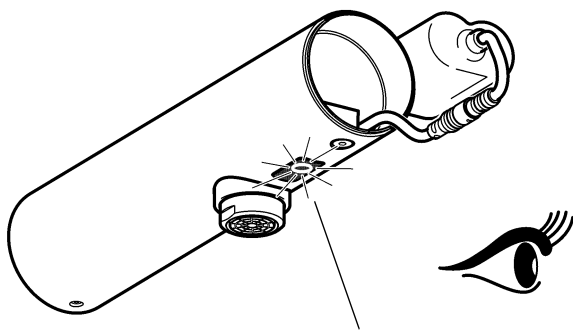

19



2x    

1x    

3.

A

B

20



20.2

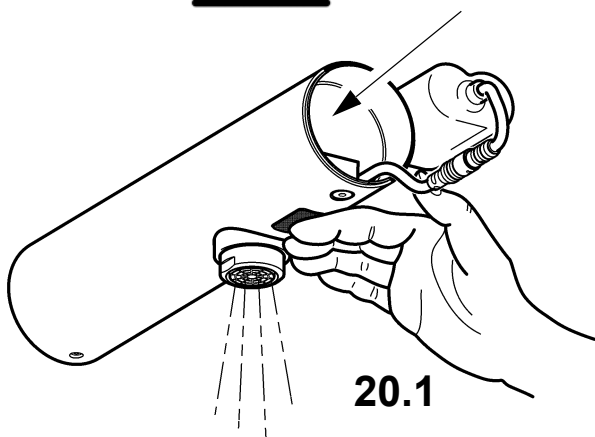

21

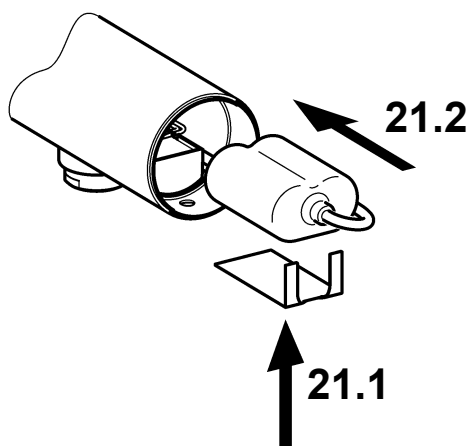

22

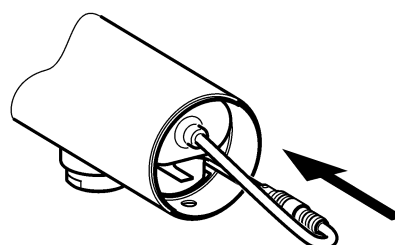

23

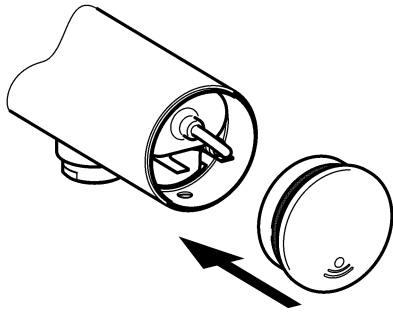

24

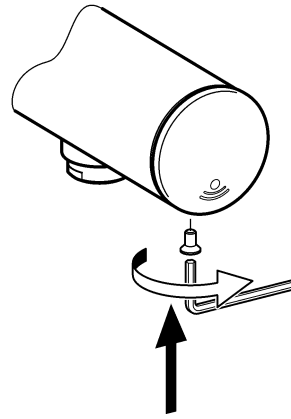

25

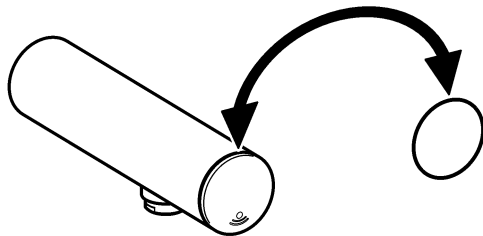

I Red

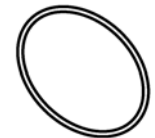

II Blue

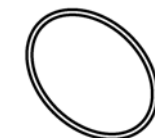

EN | Red
| Blue

ES | Rojo
| Azul

PL | Czerwony
| Niebieski

FI | Punainen
| Sininen

DE | Rot
| Blau

IT | Rosso
| Blu

SV | Röd
| Blå

RU | красный
| голубой

FR | Rouge
| Bleu

NL | Rood
| Blauw

CS | Červený
| Modrý

14. Magnetventilkartusche wechseln

EN Replacing the solenoid valve cartridge	NL Magneetventielpatroon verandering	CS Výměna kartuše s magnetickým ventilem
FR Remplacement de la cartouche d'électrovanne	PL Wymiana wkładu zaworu elektromagnetycznego	FI Magneettiventtiilipanoksen vaihtaminen
ES Cambiar cartucho de la válvula electromagnética	SV Byta magnetventilpatron	RU Замена картриджа электромагнитного клапана
IT Sostituzione della cartuccia della valvola elettromagnetica		

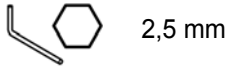

2,5 mm

1



13.

1 - **11**

2

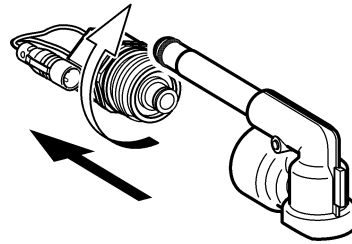

3

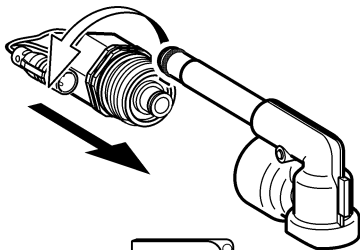

4



13.

12 - **25**

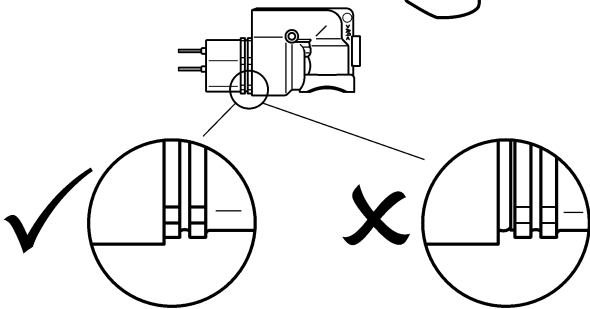

15. Batteriewechsel

EN Battery replacement
 FR Remplacement des piles
 ES Cambio de la pila
 IT Cambio delle batterie

NL Batterijen vervangen
 PL Wymiany baterii
 SV Batteribyte

CS Výměna baterie
 FI Paristonvaihto
 RU замена батареи

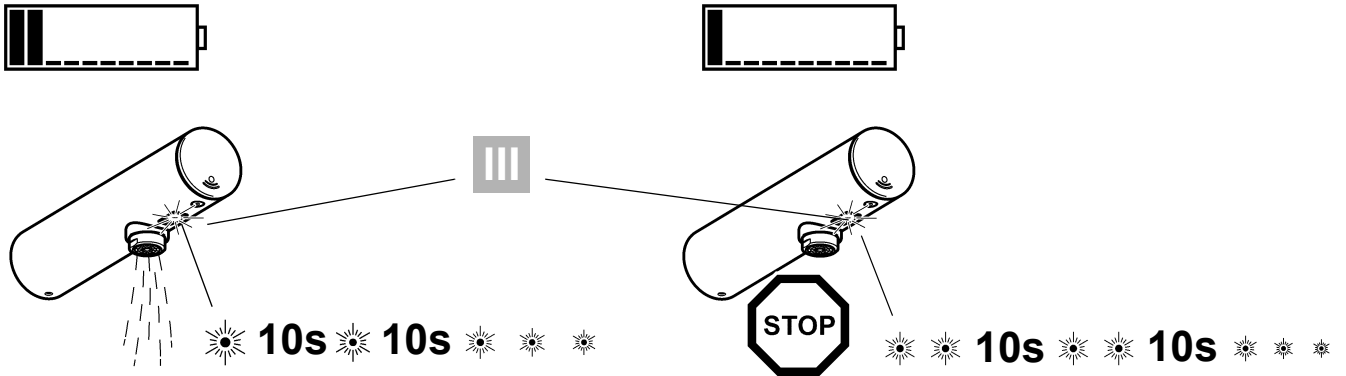

EN III Red	ES III Rojo	PL III Czerwony	FI III Punainen
DE III Rot	IT III Rosso	SV III Röd	RU III красный
FR III Rouge	NL III Rood	CS III Červený	

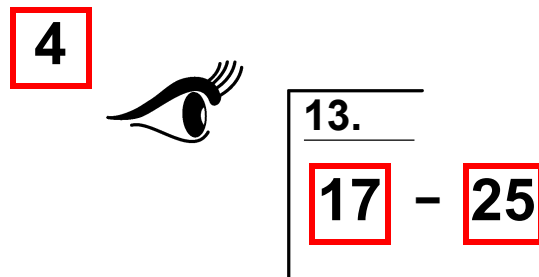
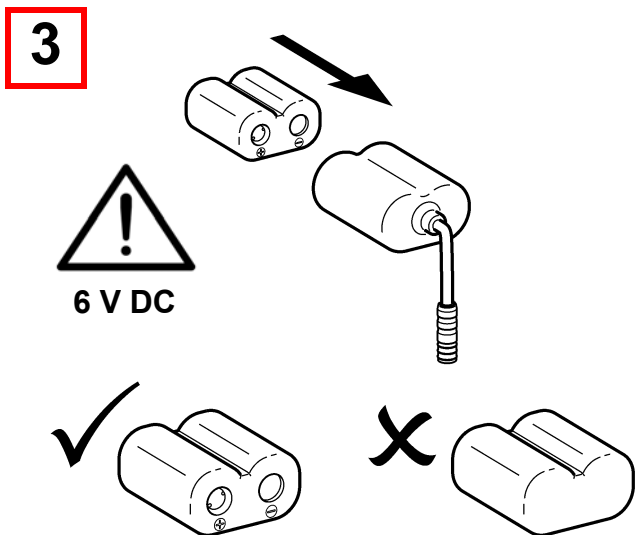
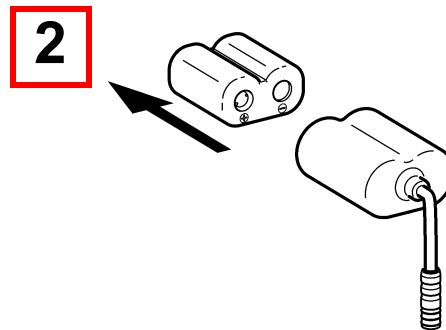
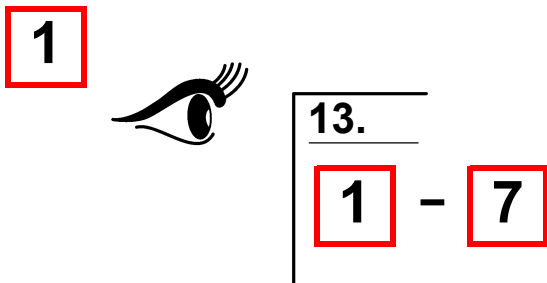

16. Ersatzteile

EN Replacement parts
FR Pièces de rechange
ES Piezas de recambio
IT Pezzi di ricambio

NL Reserveonderdelen
PL Części zamienne
SV Reservdelar

CS Náhradní díly
FI Varaosat
RU Запчасти

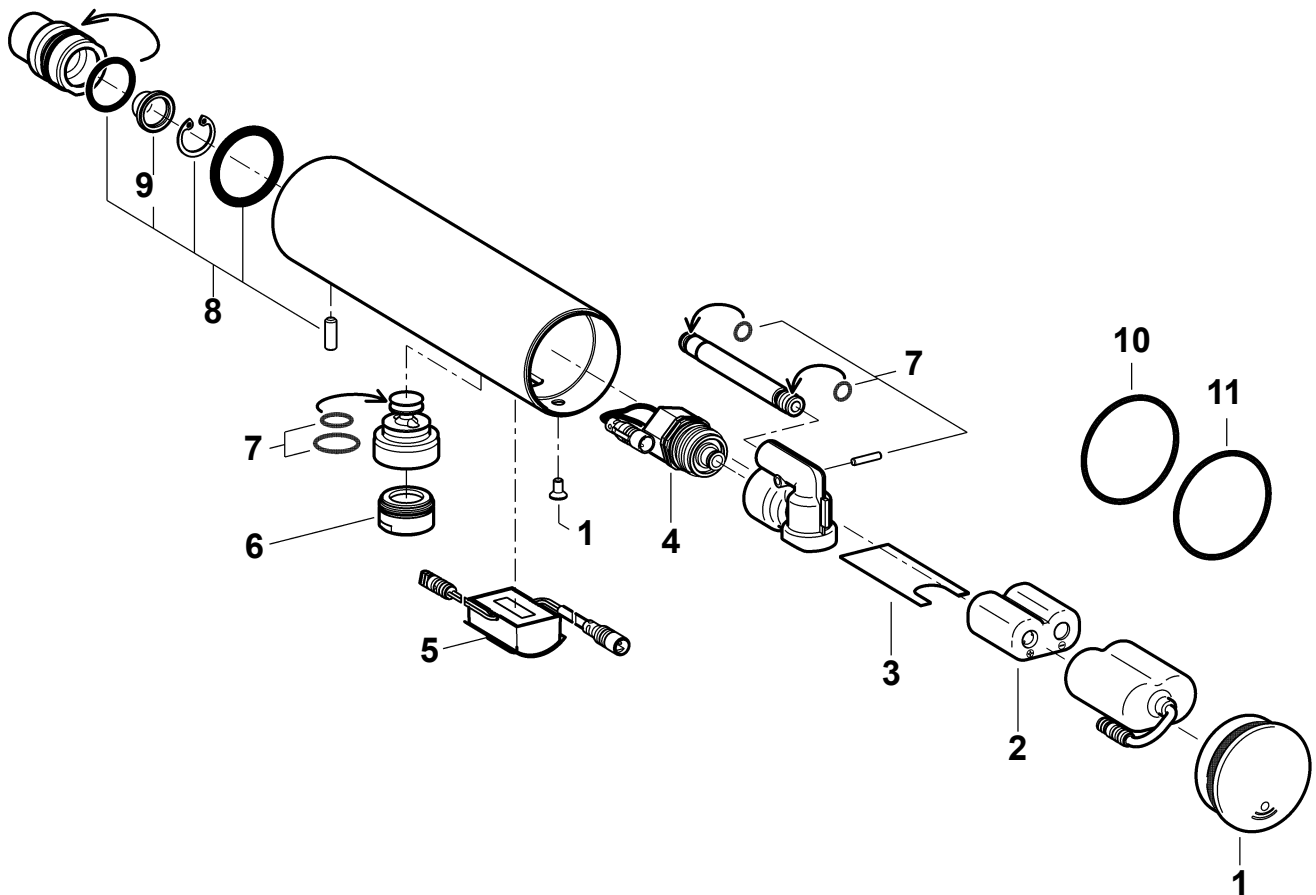

1 2030049344 ASEV1004	5 2030041447 ASEX1001	9 2000104732 a) 7612982081163
2 2000104846 EPRTR0008	6 2000104691 a) 7612982011955	10 ... 2030042439 a, b) ASEV1002
3 2030049346 a) ASEV1005	7 2030042426 ASEX1011	11 ... 2030042440 a, c) ASEV1003
4 2030045522 ACXX9002	8 2030049348 ASEV1006	

EN a) 10 pieces b) Red c) Blue	ES a) 10 piezas b) Rojo c) Azul	PL a) 10 sztuk b) Czerwony c) Niebieski	FI a) 10 kappaletta b) Punainen c) Sininen
DE a) 10 Stück b) Rot c) Blau	IT a) 10 pezzi b) Rosso c) Blu	SV a) 10 styck b) Röd c) Blå	RU a) 10 штук b) красный c) голубой
FR a) 10 pièces b) Rouge c) Bleu	NL a) 10 stuk b) Rood c) Blauw	CS a) 10 kusů b) Červený c) Modrý	

17. Zubehör

EN Accessories
FR Accessoire
ES Accesorios
IT Accessori

NL Toebehoren
PL Akcesoria
SV Tillbehör

CS Příslušenství
FI Lisävarusteet
RU принадлежности

1

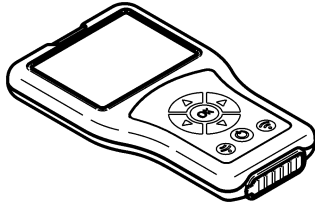

2



3

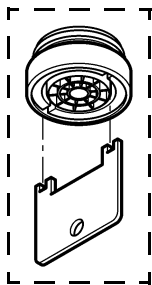

4



5

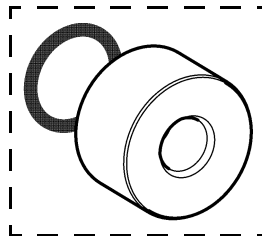

1 2030036654
ACEX9005

2 2030036849
ACEX9004

3 **6 l/min:**
2000101160
ZAQUA087

4 **3 l/min:**
2030041424 ^{a)}
ASXX1008

5 2030043823
ACEV1001

Australia

PR Kitchen and Water Systems Pty Ltd
Dandenong South VIC 3175
Phone +61 3 9700 9100

Austria

Franke GmbH
6971 Hard
Phone +43 5574 6735 0

Belgium & Luxembourg

Franke N.V.
9400 Ninove, Belgium
Phone +32 54 310 130

Czech Republic

Franke Aquarotter GmbH
14974 Ludwigsfelde, Germany
Phone +420 281 090 429

France

Franke GmbH
6971 Hard, Austria
Phone +33 800 909 216

Germany

Franke Aquarotter GmbH
14974 Ludwigsfelde
Phone +49 3378 818 0

Italy

Franke Water Systems AG
4663 Aarburg, Switzerland
Numero Verde 800 789 233

Middle East

Franke LLC
Ras Al Khaimah, United Arab Emirates
Phone +971 7 2034 700

Morocco

Franke Kitchen System SARL
21 000 Casablanca
Phone +212 522 674 200

Netherlands

Franke N.V.
9400 Ninove, Belgium
Phone +31 492 72 82 24

Poland

Franke Aquarotter GmbH
14974 Ludwigsfelde, Germany
Phone +48 58 35 19 700

Portugal

Franke Portugal S.A.
2735-531 Cacém
Phone +351 21 426 9670

South Africa & Sub Saharan Africa

Franke South Africa
Durban, 4052
Phone + 27 31 450 6300

Spain

Franke GmbH
6971 Hard, Austria
Phone +43 5574 6735 211

Switzerland & Liechtenstein

Franke Water Systems AG
4663 Aarburg
Phone +41 62 787 3131

Turkey

Franke Mutfak ve Banyo Sistemleri
Sanayi ve Ticaret A.S.
41400 Gebze Kocaeli
Phone +90 262 644 6595

United Kingdom

Franke Sissons Ltd.
Barlborough S43 4PZ
Phone +44 1246 450 255

Dart Valley Systems Ltd.

Paignton TQ4 7TW
Phone +44 1803 529 021

EAST EUROPE

**Bosnia Herzegovina | Bulgaria |
Croatia | Hungary | Latvia | Lithuania |
Romania | Russia | Serbia | Slovakia |
Slovenia | Ukraine**

Franke Aquarotter GmbH
14974 Ludwigsfelde, Germany
Phone +49 3378 818 530

NORTH AMERICA

United States | Canada

Franke Kindred Canada Limited
Midland, ON L4R 4K9, Canada
Phone +1 855 446 5663

SCANDINAVIA & ESTONIA

**Finland | Sweden | Norway |
Denmark | Estonia**

Franke Finland Oy
76850 Naarjärvi, Finland
Phone +358 15 34 111

OTHER COUNTRIES

Franke GmbH
6971 Hard, Austria
Phone +43 5574 6735 0

